

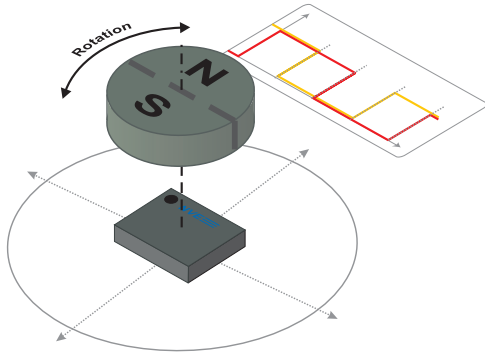

ADT001/ADT002 Rotation Sensors

ADT00X-10E Ultralow Power Rotation Sensors



Features

- Tunneling Magnetoresistance (TMR) technology
- Extremely low power (1.8 μ A typ. at 2.4 V)
- Precision digital quadrant outputs
- Wide airgap tolerance
- Operates with as little as 30 Oersteds of magnetic field
- Integrated fault detection
- 2.4 V to 5.5 V supply range
- -40°C to +125°C operating range
- Ultraminiature TDFN6 packages

Applications

- Water meters
- Rotational speed sensors
- Rotational position sensors

Functional Diagram and Pinout

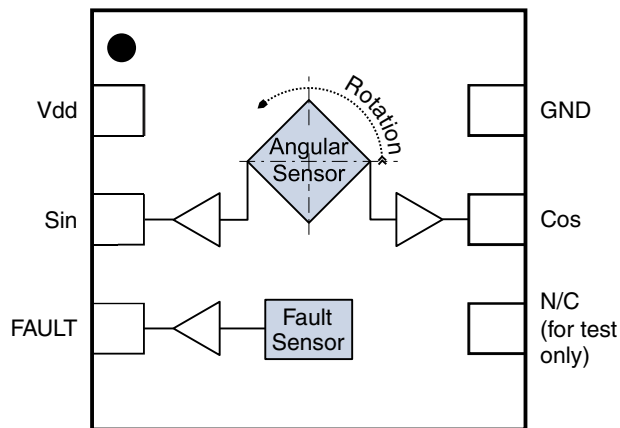

Description

The ADT001 and ADT002 rotation sensors are ultralow power, digital-output magnetic rotation sensors. Tunneling Magnetoresistance (TMR) technology allows small size and low power, making the sensors ideal for battery operation.

The sensors have two digital, binary outputs. The two outputs are 90 degrees out of phase to provide directional information.

An additional output indicates a fault if the magnetic field is too high for accurate measurements.

The ADT001 is optimized for edge-sensitive applications and the ADT002 for absolute position. The ADT001 has high hysteresis for noise immunity in applications such as speed sensing and counting rotations. The ADT002 is low hysteresis to provide accurate, absolute rotational quadrant information.

The parts are packaged in NVE's 2.5 mm x 2.5 mm x 0.8 mm TDFN6 surface-mount package.

Truth Table

| Angle | Output | |
|-----------|--------|-----|
| | Sin | Cos |
| 0°-90° | H | H |
| 90°-180° | H | L |
| 180°-270° | L | L |
| 270°-360° | L | H |



ADT001/ADT002 Rotation Sensors

Absolute Maximum Ratings

| Parameter | Min. | Max. | Units |
|------------------------|------|-----------|-------|
| Supply Voltage | -0.5 | 7 | Volts |
| Storage Temperature | -40 | 170 | °C |
| ESD (Human Body Model) | | 2000 | Volts |
| Applied Magnetic Field | | Unlimited | Oe |

Operating Specifications

| T _{min} to T _{max} ; 2.4 V < V _{DD} < 5.5 V unless otherwise stated. | | | | | | |
|---|-------------------------------------|------------------------|------|-----------------|-------|---|
| Parameter | Symbol | Min. | Typ. | Max. | Units | Test Condition |
| Operating Temperature | T _{min} ; T _{max} | -40 | | 125 | °C | |
| Supply Voltage | V _{DD} | 2.4 | | 5.5 | V | |
| Supply Current | I _{DDQ} | 0.55 | 1.8 | 3.1 | μA | V _{DD} = 2.4V |
| | | | 2.2 | | | V _{DD} = 3V |
| | | 0.8 | 2.7 | 4.6 | | 3V < V _{DD} < 3.6V |
| | | | | 6.95 | | V _{DD} = 5.5V |
| Applied Magnetic Field Strength | | 30 | | 200 | Oe | |
| Fault Output Field Strength Threshold | | 200 | 300 | 500 | Oe | Pin 4 not connected; field in any direction |
| Low-Level Output Voltage | V _{OL} | 0 | | 0.24 | V | I _L = -50 μA |
| High-Level Output Voltage | V _{OH} | V _{DD} - 0.25 | | V _{DD} | V | I _L = 50 μA |
| Angular Precision/Repeatability | | | | ±1.5 | deg. | |
| Angular Hysteresis | θ _H - θ _L | 12 | 20 | 28 | deg. | V _{DD} = 3.6V; 25°C |
| ADT001 | | 3 | 4 | 6 | | |
| ADT002 | | | | | | |
| Frequency Response | f _{MAX} | 2 | | | kHz | |

Operation

Overview

The heart of the unique sensor is an array of four Tunneling Magnetoresistance (TMR) elements, one in each quadrant. TMR technology enables low power and miniaturization, making the sensors ideal for battery operation.

In a typical configuration, an external magnet provides a saturating magnetic field (30 to 200 Oe) in the plane of the sensor, as illustrated below for a bar magnet and a radially-magnetized disk magnet:

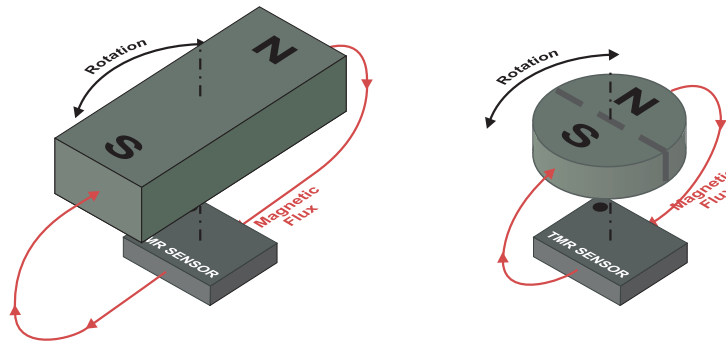

Figure 1. Sensor operation.

Simple output encoding

The rotation is encoded in two quadrature outputs, 90 degrees out of phase. Mathematically, the outputs correspond to the sign of the sine and cosine of the rotation, i.e., $\text{sgn}(\sin\theta)$ and $\text{sgn}(\cos\theta)$, as shown below:

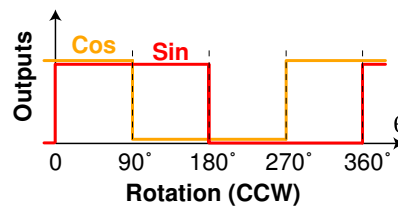

Figure 2. Sensor outputs
(counterclockwise rotation viewed from the top of the sensor).

Thus the binary sensor outputs define the quadrant of rotation:

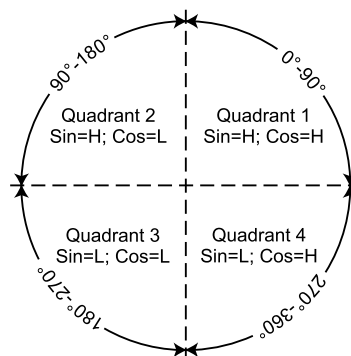

Figure 3. Sensor outputs for each rotation quadrant.

Wide range of magnets and magnet location

The sensor operates with as little as a 30 Oe magnetic field, and is accurate up to 200 Oe. This wide magnetic field range allows inexpensive magnets and operation over a wide range of magnet spacing. Larger or stronger magnets require more distance to avoid oversaturating the sensor; smaller or weaker magnets may require closer spacing. Low-cost, radially-magnetized ferrite disk magnets can be used with these sensors. Bar magnets can also be used in some configurations.

When locating the magnet in relation to the sensor, note that the rotational center of the sensor is offset slightly from the package center (see Figure 11).

Absolute position

Unlike some encoder types, ADT001/ADT002 sensors detect absolute position and maintain position information when the power is removed. The sensor immediately powers up indicating the correct position.

Power supply decoupling and noise filtering

Since ADT00X sensors are duty-cycled to reduce power consumption, a bypass capacitor should be used on V_{DD} if the sensor is powered by a power supply or a battery with long connections. 10 nF ceramic capacitors are typical.

Because the sensor uses high-impedance circuitry and often operates in noisy environments, designers should consider filtering or debounce circuitry on the sensor outputs if possible, especially if the application relies on triggering or counting edges.

Integrated fault detection

An additional output indicates a fault if the magnetic field is too high for accurate measurements. This can occur if the magnet is too close to the sensor, or due to interference from adjacent magnets. The signal can also be used to align assemblies.

The signal is intended for gross sensing since the exact threshold depends on the particular device, field orientation, and supply voltage, and can vary over temperature.

The fault detection threshold can be adjusted with an external resistor from pin 4 to ground, which increases the fault detection threshold field as shown in Figure 4:

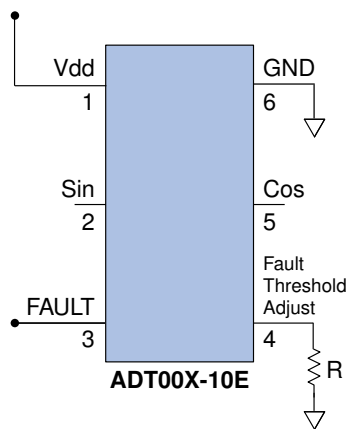

Figure 4. Fault threshold adjustment test circuit.

The typical effect of the external resistor value is shown in Figure 7.



ADT001/ADT002 Rotation Sensors

Typical Performance Graphs

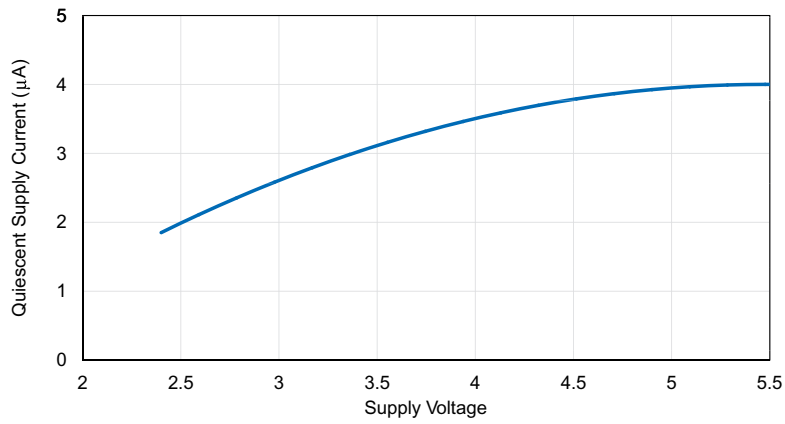

Figure 5. Typical Quiescent Supply Current (25°C).

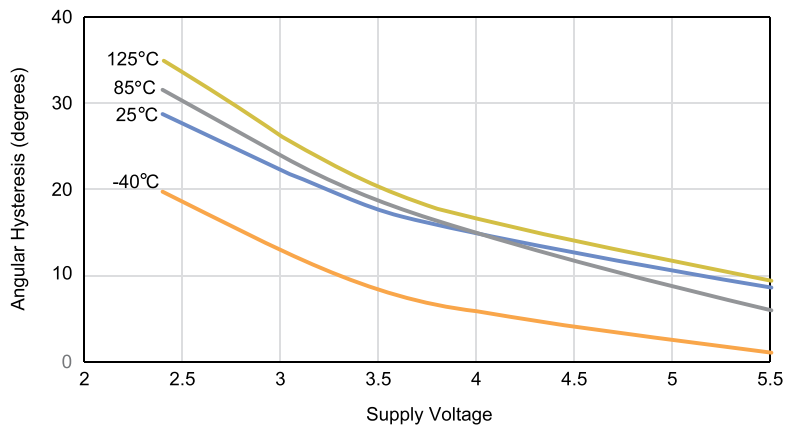

Figure 6. Typical Angular Hysteresis vs. Supply Voltage (25°C).

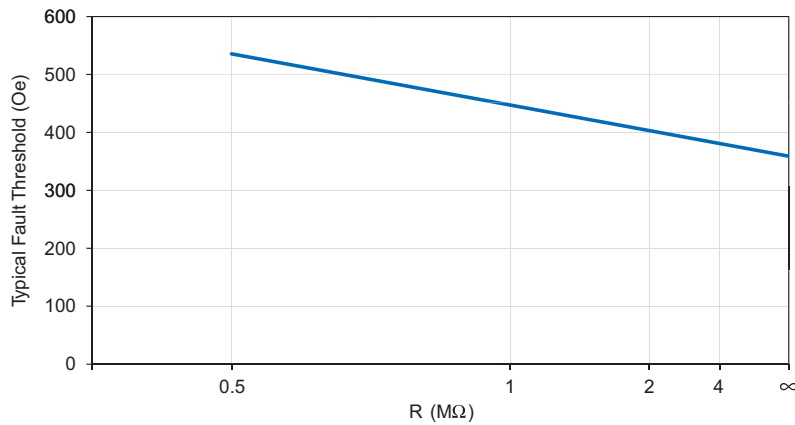

Figure 7. Typical fault threshold vs. external threshold adjust resistor (Fig. 4 test circuit).



ADT001/ADT002 Rotation Sensors

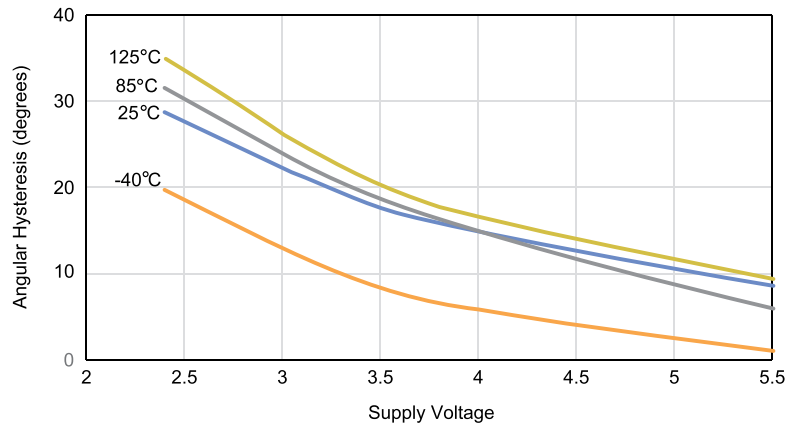

Figure 8. Typical angular hysteresis vs. supply voltage at various temperatures (ADT001).

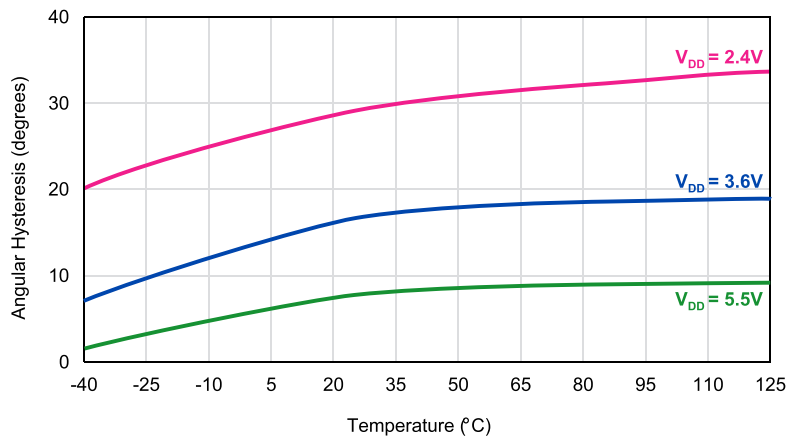

Figure 9. Typical hysteresis vs. temperature at various supply voltages (ADT001).

Illustrative Application Circuits

Quadrant detection

A 2-to-4 Line Decoder can provide digital signals indicating the quadrant of rotation:

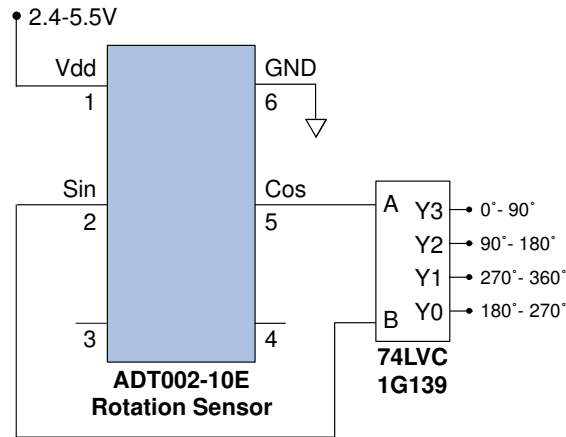

Figure 10. Quadrant detection.

Direction detection

A “D” flip-flop can be used to create a direction output by detecting the phasing between the two outputs. In the circuit below, the direction signal is updated as the Sin output goes from low-to-high, which is at zero degrees for counterclockwise rotation and 180 degrees for clockwise rotation. The resistor and capacitor enhance noise immunity for harsh environments. The ADT001 is particularly well-suited for this type of application because its high hysteresis ensures clean transitions with no possibility of false triggering on the high-to-low transition to the flip-flop clock.

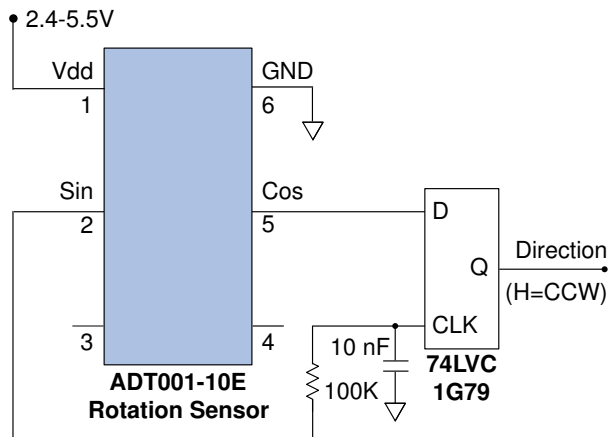

Figure 11. Direction detection.

A two-cycle/revolution signal

An Exclusive-OR gate can be used to provide a digital signal with two cycles per revolution and transitions every 90 degrees:

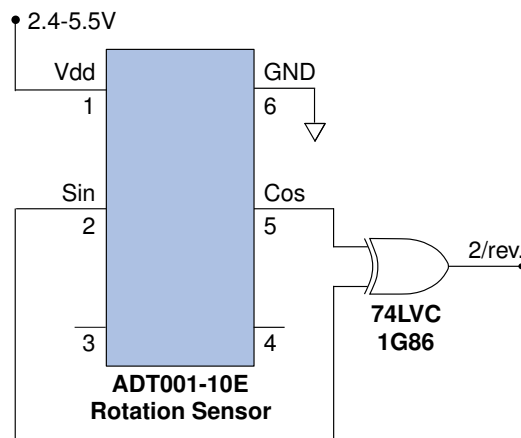

Figure 12. Two-cycle per revolution signal.

Ultralow power external circuitry

Any of the application circuits described in this section can use 74AUP-series logic instead of 74LVC circuitry if lower power is required and five-volt operation is not needed.

Pinout

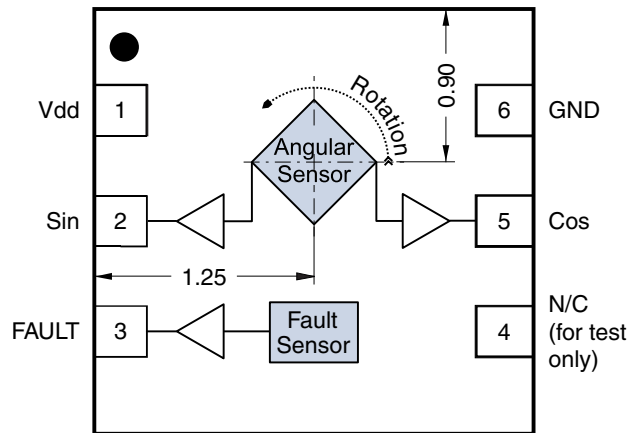

Figure 13. ADT00X-10E pinout and center of rotation.

| Pin | Symbol | Description |
|-----|------------------------|---|
| 1 | V _{DD} | Supply voltage (2.4 V to 5.5 V). |
| 2 | Sin | HIGH CMOS output when the sine of the rotation angle is positive (0 – 180°). |
| 3 | FAULT | HIGH CMOS output indicates excess magnetic field and possible unreliable measurement. |
| 4 | Fault Threshold Adjust | Connection for an optional external resistor to GND to increase the fault detection threshold field for the FAULT output. |
| 5 | Cos | HIGH CMOS output when the cosine of the rotation angle is positive (0 – 90° or 270° – 360°). |
| 6 | GND | Ground. |

Notes:

- The package center pad may be left floating or connected to ground.
- This product has been tested for electrostatic sensitivity to the limits stated in the specifications. However, NVE recommends that all integrated circuits be handled with appropriate care to avoid damage. Damage caused by inappropriate handling or storage could range from performance degradation to complete failure.

Available Parts

| Part No. | Package | Marking | Description |
|------------|---------|---------|---|
| ADT001-10E | TDFN6 | FDXe | High hysteresis, ultralow-power rotation sensor |
| ADT002-10E | TDFN6 | FDYe | Low hysteresis, ultralow-power rotation sensor |



ADT001/ADT002 Rotation Sensors

2.5 mm x 2.5 mm TDFN6 Package

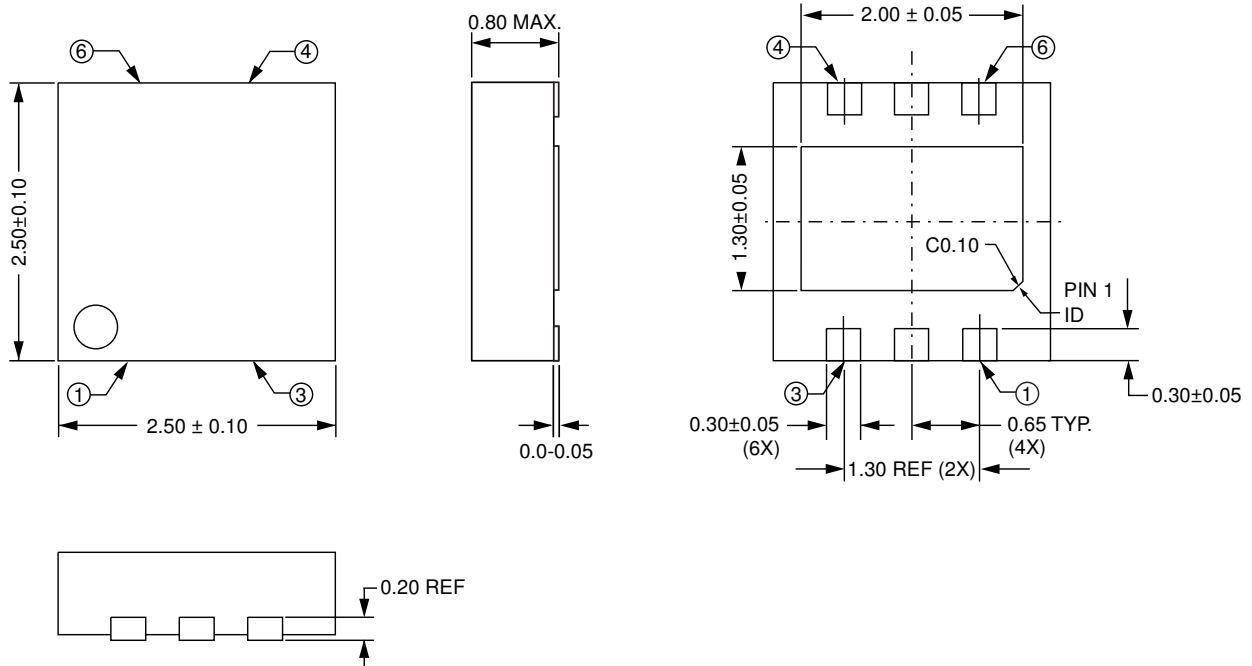

Notes:

- Dimensions in millimeters.
- Soldering profile per JEDEC J-STD-020C, MSL 1.





ADT001/ADT002 Rotation Sensors

Revision History

SB-00-048-B
April 2017

Change

- Tightened supply current spec. based on more test data.
- Clarified repeatability vs. accuracy (p. 2).
- Added performance graphs of angular hysteresis vs. temperature and supply voltage.

SB-00-048-A
Sept. 2016

Change

- Initial release.

SB-00-048-PRELIM
May 2016

Change

- Preliminary release.



ADT001/ADT002 Rotation Sensors

Datasheet Limitations

The information and data provided in datasheets shall define the specification of the product as agreed between NVE and its customer, unless NVE and customer have explicitly agreed otherwise in writing. All specifications are based on NVE test protocols. In no event however, shall an agreement be valid in which the NVE product is deemed to offer functions and qualities beyond those described in the datasheet.

Limited Warranty and Liability

Information in this document is believed to be accurate and reliable. However, NVE does not give any representations or warranties, expressed or implied, as to the accuracy or completeness of such information and shall have no liability for the consequences of use of such information.

In no event shall NVE be liable for any indirect, incidental, punitive, special or consequential damages (including, without limitation, lost profits, lost savings, business interruption, costs related to the removal or replacement of any products or rework charges) whether or not such damages are based on tort (including negligence), warranty, breach of contract or any other legal theory.

Right to Make Changes

NVE reserves the right to make changes to information published in this document including, without limitation, specifications and product descriptions at any time and without notice. This document supersedes and replaces all information supplied prior to its publication.

Use in Life-Critical or Safety-Critical Applications

Unless NVE and a customer explicitly agree otherwise in writing, NVE products are not designed, authorized or warranted to be suitable for use in life support, life-critical or safety-critical devices or equipment. NVE accepts no liability for inclusion or use of NVE products in such applications and such inclusion or use is at the customer's own risk. Should the customer use NVE products for such application whether authorized by NVE or not, the customer shall indemnify and hold NVE harmless against all claims and damages.

Applications

Applications described in this datasheet are illustrative only. NVE makes no representation or warranty that such applications will be suitable for the specified use without further testing or modification.

Customers are responsible for the design and operation of their applications and products using NVE products, and NVE accepts no liability for any assistance with applications or customer product design. It is customer's sole responsibility to determine whether the NVE product is suitable and fit for the customer's applications and products planned, as well as for the planned application and use of customer's third party customers. Customers should provide appropriate design and operating safeguards to minimize the risks associated with their applications and products.

NVE does not accept any liability related to any default, damage, costs or problem which is based on any weakness or default in the customer's applications or products, or the application or use by customer's third party customers. The customer is responsible for all necessary testing for the customer's applications and products using NVE products in order to avoid a default of the applications and the products or of the application or use by customer's third party customers. NVE accepts no liability in this respect.

Limiting Values

Stress above one or more limiting values (as defined in the Absolute Maximum Ratings System of IEC 60134) will cause permanent damage to the device. Limiting values are stress ratings only and operation of the device at these or any other conditions above those given in the recommended operating conditions of the datasheet is not warranted. Constant or repeated exposure to limiting values will permanently and irreversibly affect the quality and reliability of the device.

Terms and Conditions of Sale

In case an individual agreement is concluded only the terms and conditions of the respective agreement shall apply. NVE hereby expressly objects to applying the customer's general terms and conditions with regard to the purchase of NVE products by customer.

No Offer to Sell or License

Nothing in this document may be interpreted or construed as an offer to sell products that is open for acceptance or the grant, conveyance or implication of any license under any copyrights, patents or other industrial or intellectual property rights.

Export Control

This document as well as the items described herein may be subject to export control regulations. Export might require a prior authorization from national authorities.

Automotive Qualified Products

Unless the datasheet expressly states that a specific NVE product is automotive qualified, the product is not suitable for automotive use. It is neither qualified nor tested in accordance with automotive testing or application requirements. NVE accepts no liability for inclusion or use of non-automotive qualified products in automotive equipment or applications.

In the event that customer uses the product for design-in and use in automotive applications to automotive specifications and standards, customer (a) shall use the product without NVE's warranty of the product for such automotive applications, use and specifications, and (b) whenever customer uses the product for automotive applications beyond NVE's specifications such use shall be solely at customer's own risk, and (c) customer fully indemnifies NVE for any liability, damages or failed product claims resulting from customer design and use of the product for automotive applications beyond NVE's standard warranty and NVE's product specifications.



ADT001/ADT002 Rotation Sensors

An ISO 9001 Certified Company

NVE Corporation
11409 Valley View Road
Eden Prairie, MN 55344-3617 USA
Telephone: (952) 829-9217
Fax: (952) 829-9189
www.nve.com
e-mail: sensor-info@nve.com

©NVE Corporation
All rights are reserved. Reproduction in whole or in part is prohibited without the prior written consent of the copyright owner.

SB-00-048_AD T00X-10E_RevB

Jan. 2019

Headquarter Switzerland:
Angst+Pfister Sensors and Power AG

Thurgauerstrasse 66
CH-8050 Zurich
Phone +41 44 877 35 00
sensorsandpower@angst-pfister.com

Office Germany:
Angst+Pfister Sensors and Power
Deutschland GmbH
Edisonstraße 16
D-85716 Unterschleißheim
Phone +49 89 374 288 87 0
sensorsandpower.de@angst-pfister.com



We are here for you. Addresses and Contacts.

Sales Germany & Austria

Geometrical sensors
Other products

Kurt Stritzelberger
Phone +49 89 374 288 87 22
kurt.stritzelberger@angst-pfister.com

Pressure sensors
Other products

Gerhard Vetter
Phone +49 89 374 288 87 26
gerhard.vetter@angst-pfister.com

Gas sensors and modules

Peter Felder
Phone +41 44 877 35 05
peter.felder@angst-pfister.com

Sales Switzerland & Liechtenstein

Postcode 3000 – 9999

Basil Frei
Phone +41 44 877 35 18
basil.frei@angst-pfister.com

Postcode 1000 – 2999

Christian Mohrenstecher
Phone +41 76 444 57 93
christian.mohrenstecher@angst-pfister.com

Sales International Key Accounts

Peter Felder
Phone +41 44 877 35 05
peter.felder@angst-pfister.com

Sales Other Countries / Product Management

Pressure Sensors
Load Cells

Philipp Kistler
Phone +41 44 877 35 03
philipp.kistler@angst-pfister.com

Gas sensors
Gas sensor modules

Dr. Thomas Clausen
Phone +49 89 374 288 87 24
thomas.clausen@angst-pfister.com

Flow / Level / Medical products

Dr. Adriano Pittarelli
Phone +49 89 374 288 87 67
adriano.pittarelli@angst-pfister.com

Power supplies

Sebastiano Leggio
Phone +41 44 877 35 06
sebastiano.leggio@angst-pfister.com

Linear position sensors
Angle sensors

Eric Letsch
Phone +41 44 877 35 14
eric.letsch@angst-pfister.com

Accelerometers
Sensor elements

Christoph Kleye
Phone +49 89 374 288 87 61
christoph.kleye@angst-pfister.com

Drive technology
CH Postcode 5000 – 9999 / DE

Roman Homa
Phone +41 76 444 00 86
roman.homa@angst-pfister.com

Drive technology
CH Postcode 1000 – 4999 / AT / IT / FR

Christian Mohrenstecher
Phone +41 76 444 57 93
christian.mohrenstecher@angst-pfister.com

Harald Thomas
Phone +49 89 374 288 87 23
harald.thomas@angst-pfister.com