

## Electrochemical Sensors Application Note 2

### Design of Electronics for Electrochemical Gas Sensors

#### INTRODUCTION

This application note gives guidance on the design of electronic circuits for use with SGX Sensortech electrochemical gas sensors. There are 4 types of circuits required for the range of sensors:

- i. For sensors which have 3 electrodes, (the majority of sensors for detecting toxic gases and EC410 Oxygen sensor), the circuit required is known as a potentiostatic circuit. This circuit can either have the sensing and reference electrodes at the same potential (non-biased) or the sensing and reference held at different voltages (a biased sensor). These circuits are described in section 1.
- ii. For the dual CO & H<sub>2</sub>S sensor, which has 4 electrodes, a modified 2 channel potentiostatic circuit is used. This is described in section 2.
- iii. For the 2 electrode toxic sensors (e.g. SureCO) a simpler circuit is required. This is described in section 3.
- iv. For the SGX-40X and SGX-70X oxygen sensors the standard circuit for lead based oxygen sensors is required. This is described in section 4.

The information is provided for general advice and care should be taken to adapt the circuits to the particular requirements of the application. By following the recommendations of this application note the user should be able to achieve excellent performance with SGX electrochemical gas sensors.

#### SECTION 1: CIRCUIT FOR 3 ELECTRODE TOXIC SENSORS AND THE EC410

Figure 1 shows the outline block diagram of a typical gas detection system using an electrochemical gas sensor.

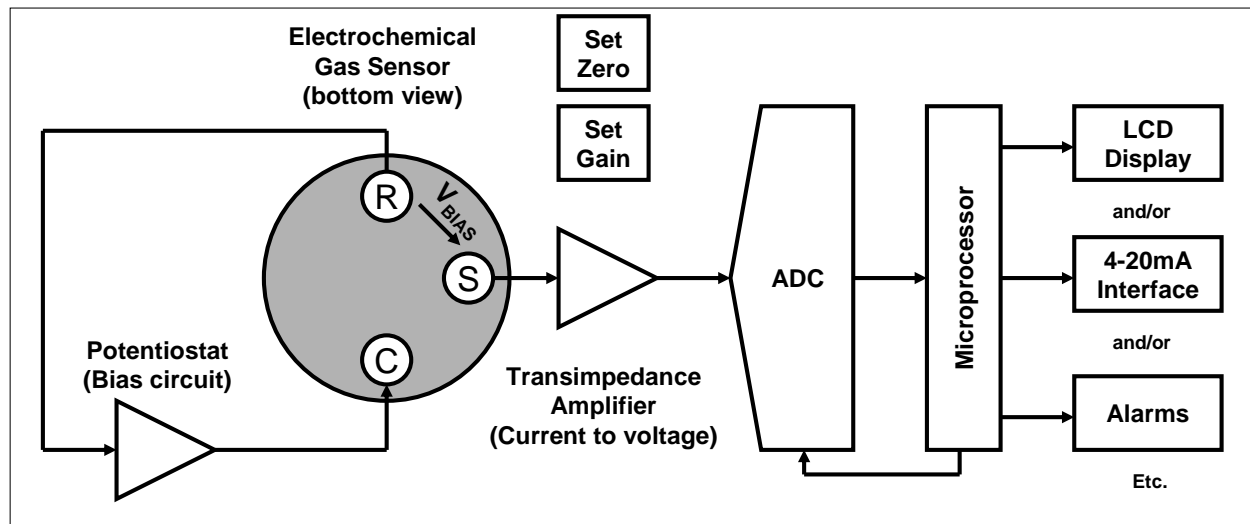

Figure 1 – Block Diagram of Typical Gas Detection System using an Electrochemical Gas Sensor

- R: Reference Electrode  
 C: Counter Electrode  
 S: Sensing Electrode (sometimes called the 'Working' electrode)

Whilst SGX has taken care to ensure the accuracy of the information contained herein it accepts no responsibility for the consequences of any use thereof and also reserves the right to change the specification of goods without notice. SGX accepts no liability beyond the set out in its standard conditions of sale in respect of infringement of third party patents arising from the use of SGX products in accordance with information contained herein. In case of modification of the product, SGX disclaims all liability.

## Electrochemical Sensors Application Note 2 Design of Electronics for Electrochemical Gas Sensors

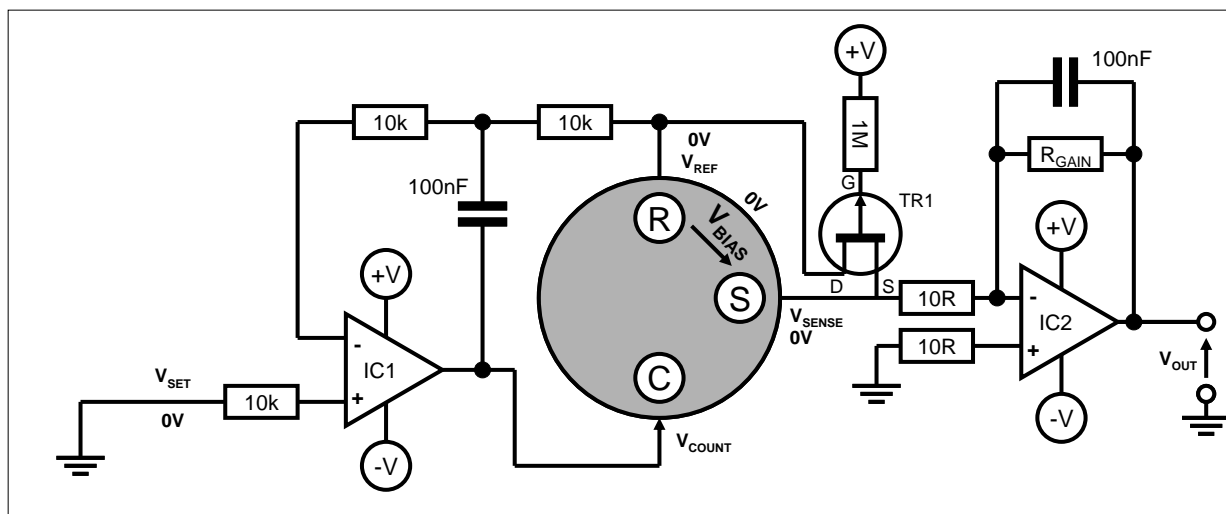

Figure 2 – Unbiased Sensor Circuit with Split Power Rails

### UNBIASED SENSOR CIRCUIT (Figure 2)

#### Introduction to Biasing

The purpose of the sensor bias circuit (potentiostat) is to maintain the potential of the sensing electrode at a constant level with respect to the reference electrode. This is done by adjusting the voltage of a third 'counter' electrode.

The required bias level ( $V_{SENSE} - V_{REF}$ ) varies according to sensor type and can be found on the relevant datasheet. It is summarised here for reference:

Sensor	Applied bias ( $V_{SENSE} - V_{REF}$ )	$V_{OUT}$ Polarity
EC4-1-CIO2	0 V	Negative
EC4-50-CIO2	0 V	Negative
EC4-200-CI2	0 V	Negative
EC4-500-CO	0 V	Positive
EC4-2000-CO	0 V	Positive
EC4-10-ETO	+300 mV	Positive
EC4-1000-H2	0 V	Positive
EC4-100-H2S	0 V	Positive
EC4-1000-H2S	0 V	Positive
EC4-250-NO	+300 mV	Positive
EC4-2000-NO	+300 mV	Positive
EC4-20-NO2	0 V	Negative
EC4-20-SO2	0 V	Positive
EC4-2000-SO2	0 V	Positive
EC410 (O2)	-600 mV	Negative
SGX-4CO	0 V	Positive
SGX-4H2S	0 V	Positive
SGX-4DT	0 V	Positive
SGX-4NH3	0 V	Positive
SGX-4OX	0 V	Positive
SGX-4NO2	0 V	Negative
SGX-7CO	0 V	Positive
SGX-7H2S	0 V	Positive
SGX-7NH3	0 V	Positive
SGX-7OX	0 V	Positive
SGX-SureCO	0 V	Positive

Table 1 – Bias Potential for SGX Sensors

#### Potentiostat Circuit

Figure 2 shows a typical potentiostat circuit using a positive and negative supply voltage. This configuration is simplest to explain but it can easily be adapted for single supply operation and this is described later.

Operational amplifier IC1 monitors the potential of the reference electrode,  $V_{REF}$  and applies an appropriate potential  $V_{COUNT}$  to the counter electrode to keep  $V_{REF}$  equal to  $V_{SET}$ . This potential will change as the gas concentration changes because it is supplying current into the counter electrode to balance the output current from the sensing electrode.

The majority of electrochemical sensors are 'unbiased' and so  $V_{SET} = 0V$ . The potential of the sensing electrode is also held at 0V by the biasing effect of the output circuit so the result is zero bias between the  $V_{SENSE}$  and  $V_{REF}$ .

#### Maintaining Zero Bias during Power Down

TR1, a P-channel FET, maintains the zero bias between sensing and reference electrodes when the supply voltage is turned off. A low voltage on the gate causes the FET to conduct so that  $V_{REF} = V_{SENSE}$ . Holding this 0V bias during power down enables the sensor to stabilise very quickly when the power is turned on again.

When the circuit power is reconnected, a high voltage on the gate of TR1 will cause the FET to stop conducting so that the op-amp can control the bias. TR1 should be chosen to have a positive gate-source cut-off voltage  $V_{GS(OFF)}$  which is lower than the supply voltage. Transistors such as the J177 (lead) or MMBFJ177 (surface mount) are often used. If a shorting FET is not used, the sensor may take a few hours to re-stabilise after turn-on.

## Electrochemical Sensors Application Note 2

### Design of Electronics for Electrochemical Gas Sensors

#### Output Polarity

The output of electrochemical sensors is a current proportional to the gas concentration. For most gases electrons flow *out* of the sensing electrode (i.e. conventional current flows *into* the sensing electrode) which results in a positive output voltage from the circuit. However, for gases which undergo a reduction in the cell ( $\text{ClO}_2$ ,  $\text{CL}_2$ ,  $\text{NO}_2$  and  $\text{O}_2$ ), electrons flow *into* the sensing electrode (conventional current flows *out*) which results in a negative voltage from the circuit. See Table 1 for a summary.

#### Transimpedance Amplifier

The output current of the electrochemical sensor must be converted to a voltage using a transimpedance (current to voltage) amplifier. Figure 2 shows operational amplifier IC2 connected in this mode.

A 10R load resistor is recommended in series with the sense electrodes. This resistor forms an RC smoothing filter with the intrinsic sensor capacitance. It is possible to improve the response time by reducing the value of load resistor, but at the expense of higher output noise.

$R_{\text{GAIN}}$  defines the gain of the amplifier in V/A. For example, if  $R_{\text{GAIN}} = 10\text{k}$  then:

$$\text{Transimpedance gain} = 10^4 \text{ V/A}$$

From the sensor datasheet (e.g. EC4-250-NO):

$$\begin{aligned} \text{Sensor sensitivity} &= 400 \text{ nA/ppm} \\ &= 4 \times 10^{-7} \text{ A/ppm} \end{aligned}$$

Then the system sensitivity is calculated as:

$$\begin{aligned} \text{System sensitivity} &= 4 \times 10^{-7} \times 10^4 \text{ V/ppm} \\ &= 4 \times 10^{-3} \text{ V/ppm} \\ &= 4 \text{ mV/ppm} \end{aligned}$$

It should be noted that the sensor datasheets give a range for the sensitivity. The gain resistor should be selected so that the output does not saturate at the maximum gas concentration in your application using a sensor with maximum sensitivity.

A capacitor may be fitted in parallel with the gain resistor to provide a high frequency cut-off to reduce any noise on the output.

The sensitivity will be found to reduce slightly over time (long-term output drift) and a figure is given on individual sensor datasheets. This change is typically less than 2% per month.

#### BIASED SENSOR CIRCUIT (Figure 3)

Figure 3 shows a potentiostat circuit for a biased sensor. This circuit is designed to provide a bias of +300 mV between the sense and reference electrodes by using a -300 mV  $V_{\text{SET}}$  supply.

Operational amplifier IC1 monitors the potential of the reference electrode,  $V_{\text{REF}}$  and applies an appropriate potential  $V_{\text{COUNT}}$  to the counter electrode to keep  $V_{\text{REF}}$  equal to  $V_{\text{SET}}$  (-300 mV).

The potential of the sensing electrode is held at 0 V by the biasing effect of the output circuit so the result is a +300 mV bias between  $V_{\text{SENSE}}$  and  $V_{\text{REF}}$ .

This +300 mV biasing arrangement is suitable for NO and ETO sensors. For oxygen sensors which require a -600 mV bias between  $V_{\text{SENSE}}$  and  $V_{\text{REF}}$  it is necessary to use  $V_{\text{SET}} = +600 \text{ mV}$ . In this case the  $V_{\text{SET}}$  supply would be connected between +V and ground.

**WARNING:** Applying an incorrect bias voltage may damage the sensor.

#### Maintaining Positive/Negative Bias When Off

In some instruments the power to the bias circuit is deliberately maintained even when the instrument is turned off. This keeps the bias across the sensor so that it is stable and ready to use immediately the instrument is switched on. A backup supply such as a coin cell might be used for this purpose. The shorting transistor is not used in this situation.

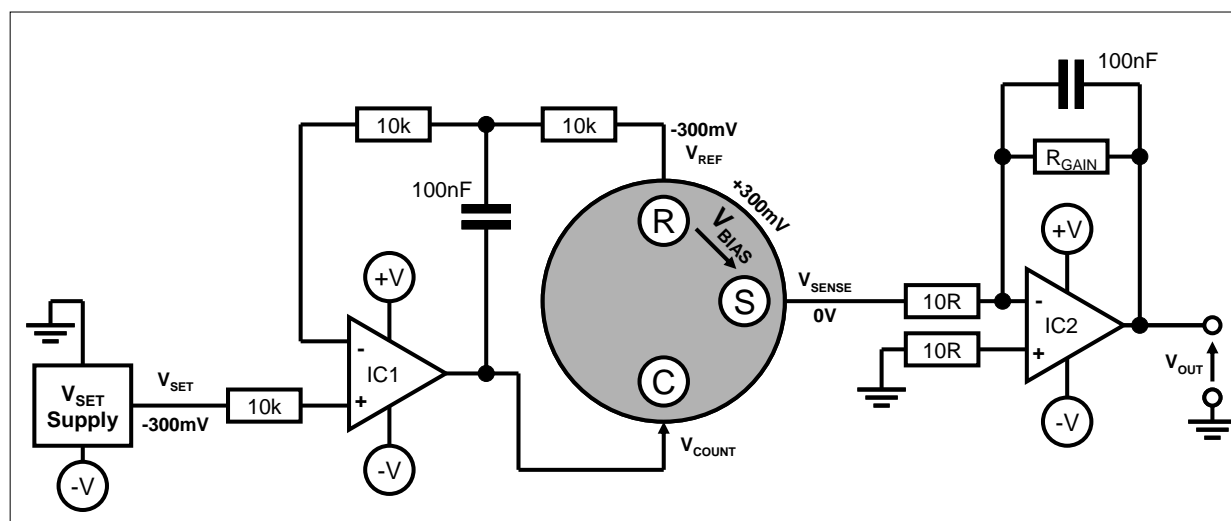

Figure 3 – Biased Sensor Circuit with Split Power Rails

## Electrochemical Sensors Application Note 2 Design of Electronics for Electrochemical Gas Sensors

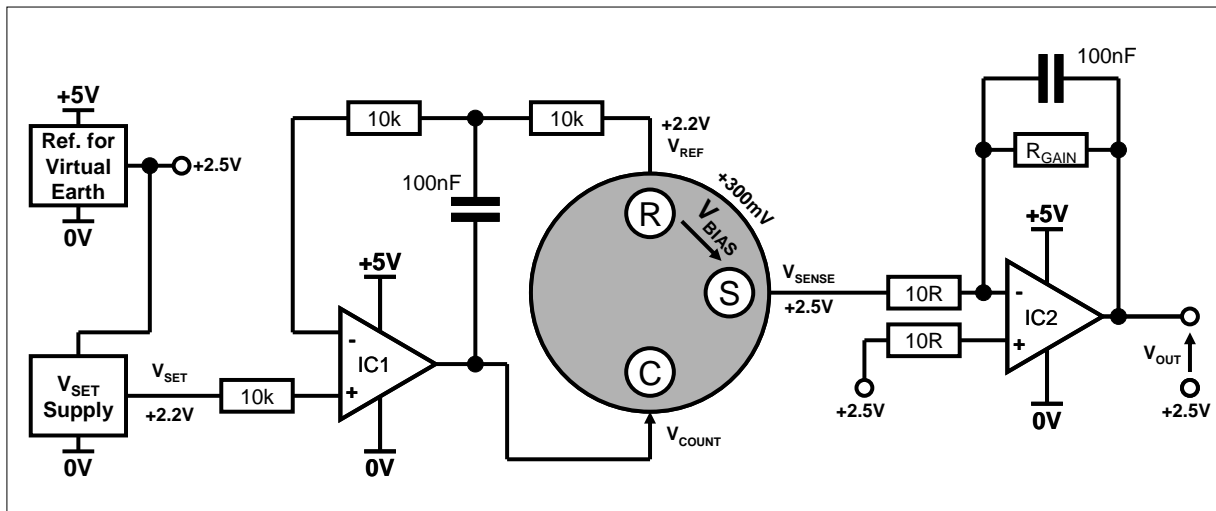

Figure 4 –Biased Sensor Circuit with Single Power Rail

### BIASED SENSOR CIRCUIT WITH SINGLE SUPPLY (Figure 4)

Figure 4 shows another potentiostat circuit for a biased sensor but this time using a single 5 V supply. It is necessary to generate a virtual ground which is typically at half the supply voltage, in this case 2.5 V. A stable voltage reference should be used to generate the virtual ground.

The virtual ground is used to reference the output circuit so the sensing electrode will also be at 2.5 V. In order to achieve a +300 mV bias between  $V_{SENSE}$  and  $V_{REF}$ , it is necessary to have  $V_{SET}$  at 300 mV below the virtual earth. Therefore  $V_{SET} = 2.200$  V.

The circuit can be adapted for even lower supply voltages but it may be necessary to change the virtual earth voltage to allow enough voltage swing. For example: an oxygen sensor requires a -600 mV bias so the reference electrode will be 600 mV above the virtual earth. The counter electrode may be another 1.1 V higher than the reference electrode which now totals 1.7 V above the virtual earth. If the supply voltage is 3 V it would be necessary to use a 1.25 V reference or lower for the virtual earth.

The above example also highlights the importance of using op-amps with a rail-to-rail output swing with low voltage power supplies. The next section gives advice on choosing a suitable operational amplifier.

### OPERATIONAL AMPLIFIER SELECTION

Several parameters should be taken into account when choosing the operational amplifier for the bias circuit:

#### Input Bias Current

Ideally the potentiostat operational amplifier should not draw any current from the reference electrode. In practice the op-amp has an 'input bias current' and if this is too large it will affect the output current from the sensing (working) electrode, particularly at low gas concentrations. A general rule is to select an op-amp with an input bias current of less than 5 nA.

#### Input Offset Voltage

When the power is off the zero bias is clamped by the transistor TR1. However, when the power is turned on the zero bias is then maintained by the potentiostat circuit. A significant input offset voltage in the op-amp IC1 will cause a sudden small step in the actual bias on the sensor. Electrochemical sensors are sensitive to even small changes in bias voltage which can cause significant currents to flow because of the sensor's large capacitance. The sensor could take several hours to stabilise after a change in bias. Select an op-amp with an input offset voltage below 100  $\mu$ V if possible, being particularly careful to check the offset the maximum operating temperature.

#### Input Offset Voltage Temperature Drift

The input offset voltage of the operational amplifier will change with temperature which results in a slight change in bias voltage. Therefore it is advisable to choose an op-amp with low input offset voltage temperature drift.

#### Output Voltage Swing

Careful consideration should be given to the required output swing for the operational amplifier particularly in low voltage systems.

The output of the potentiostat op-amp supplies the voltage to the counter electrode. This will change according to gas type and concentration. It is recommended that the op-amp be able to drive at least 1.1 V either side of  $V_{SET}$ . In low voltage circuits this will typically require an op-amp with rail-to-rail outputs.

#### Output Current Drive

The output of the potentiostat op-amp supplies a current into or out of the counter electrode which matches the current out of or into the sensing output electrode. Refer to the sensor datasheets to determine the maximum possible current in your application and the direction of current flow. Ensure that the selected op-amp is capable of sourcing or sinking the required current.

## Electrochemical Sensors Application Note 2

### Design of Electronics for Electrochemical Gas Sensors

#### CALIBRATION

##### Set Zero

It will be necessary to set the zero point when zero gas (clean air) is applied to the sensor. This can be done in hardware by offsetting the voltage at the non-inverting input of IC2. However, if the output goes to a Digital-to-Analog Converter (DAC) and a microprocessor then it will be easiest to store a zero point in software as part of a calibration routine.

For an oxygen sensor it is not always necessary to set a zero because the normal operating point is near the maximum span. However, for increased accuracy the zero offset can be obtained using one of the following methods:

- Apply pure nitrogen and measure the output.
- Assume an offset of 30  $\mu\text{A}$  at zero concentration (10% of reading at 21%).

##### Set Sensitivity

The sensitivity of the circuit (mV/ppm) can be changed by adjusting  $R_{\text{GAIN}}$ . This is done when a known concentration of gas is applied to the sensor. In an instrument with a microprocessor, the sensitivity can be adjusted in software as part of the calibration routine.

##### Temperature and Pressure Compensation

For increased accuracy, instruments may also compensate for the effects of ambient temperature and pressure.

#### BIAS CIRCUITS

Where a bias voltage is required it is important that the bias voltage is very stable. Small transient changes in bias voltage can affect the sensor output for many hours.

The bias voltage should be generated using a stable reference device such as a series or shunt voltage reference. The reference should be generated relative to the ground (split supply circuits) or virtual ground (single supply circuits).

Figures 5 and 6 shows examples of generating  $-300\text{ mV}$  (for a  $+300\text{ mV}$  biased sensor) and  $+600\text{ mV}$  (for a  $-600\text{ mV}$  biased sensor) using a  $1.225\text{ V}$  shunt voltage, reference such as the LM4041 or LM4051. These are examples and the circuit operation should be checked carefully for the particular supply voltage and the selected reference device.

Finally, Figure 7 shows how an operational amplifier can be used to generate a virtual ground from a single supply.

#### CIRCUIT LAYOUT

It is recommended to keep all PCB track lengths very short, especially in the potentiostat and transimpedance amplifier circuits. Operational amplifiers should be well decoupled close to the IC. Further noise reduction can be obtained by over-sampling the output signal and averaging the data.

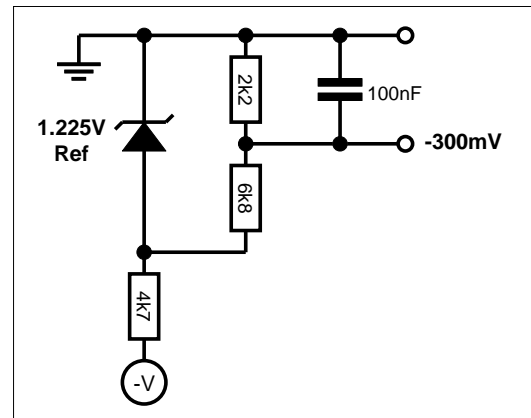

Figure 5 – Example Bias Circuit for  $-300\text{mV}$

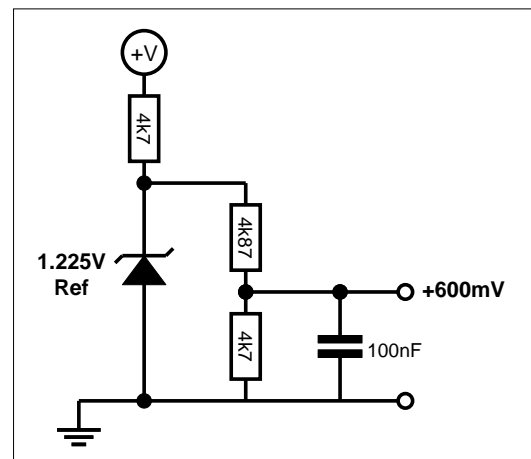

Figure 6 – Example Bias Circuit for  $+600\text{mV}$

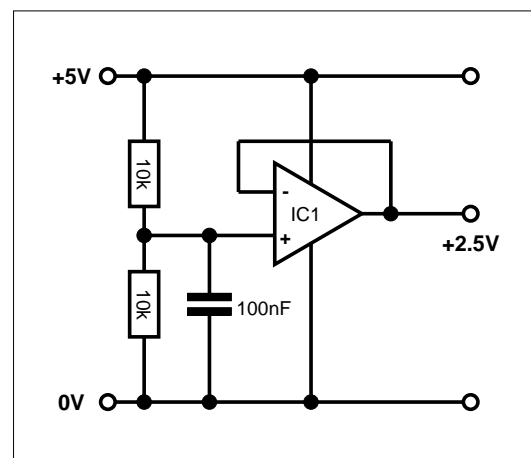

Figure 7 – Example Circuit to Generate Virtual Ground



## Electrochemical Sensors Application Note 2 Design of Electronics for Electrochemical Gas Sensors

### SECTION 2: CIRCUIT FOR SGX-4DT 4-ELECTRODE DUAL CO & H2S SENSOR

As this sensor is a dual sensor the circuit is basically duplicated. See circuit below

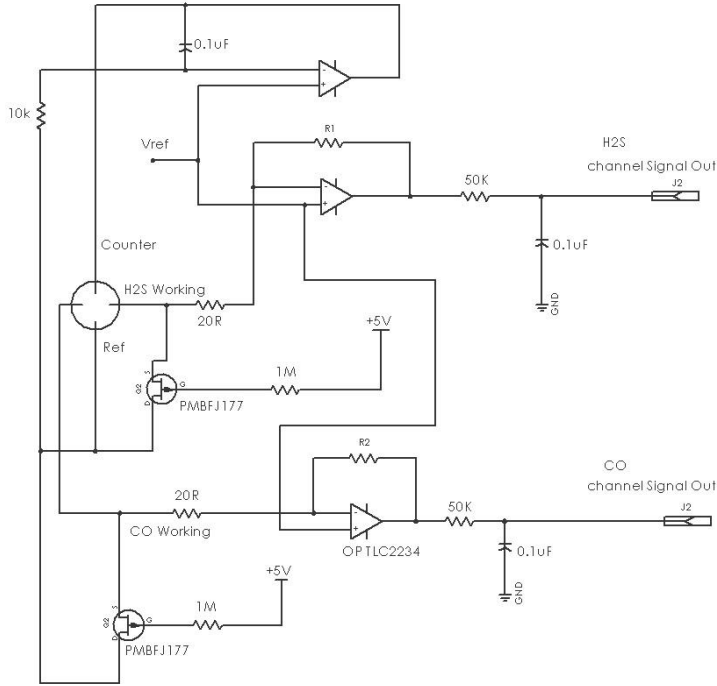

### SECTION 3: CIRCUIT FOR THE 2 ELECTRODE TOXIC SENSORS (e.g. SureCO)

Below is the circuit for the 2 pin Toxic sensors.

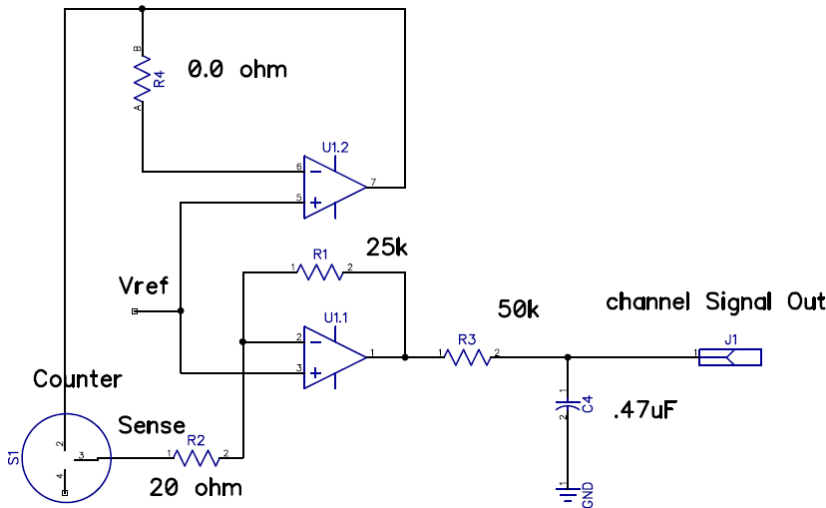



## Electrochemical Sensors Application Note 2 Design of Electronics for Electrochemical Gas Sensors

### SECTION 4: CIRCUIT FOR THE SGX-40X AND SGX-70X OXYGEN SENSORS

These sensors produce currents, in the micro-amp range, which are proportional to the concentration of oxygen present. The sensor output can therefore be easily measured by arranging a load resistor across the terminals and measuring the voltage across the resistor.

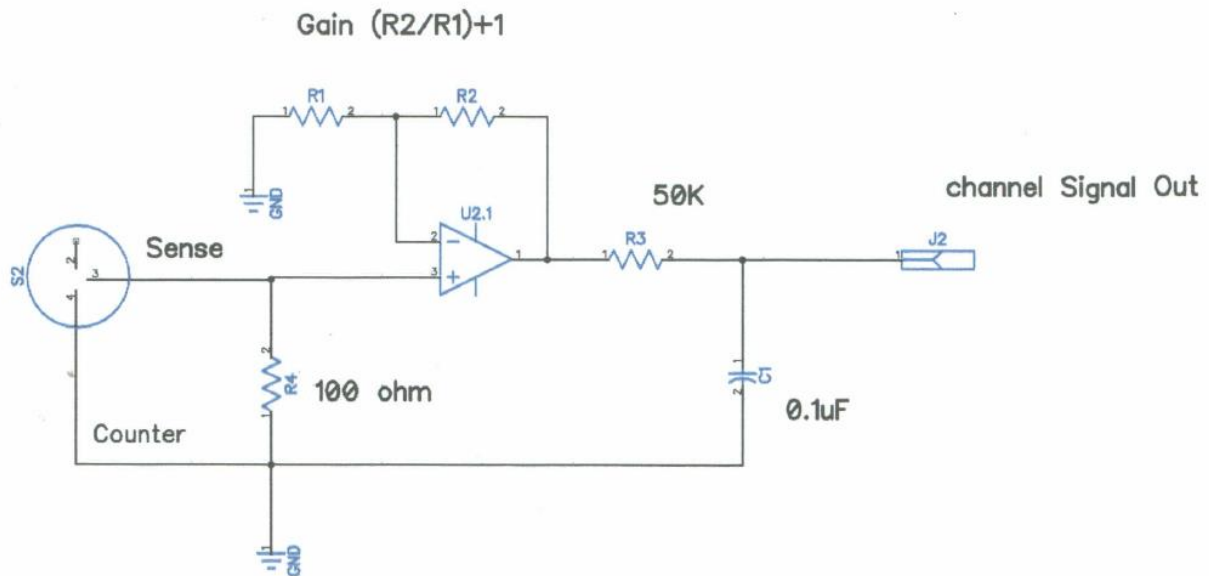

Headquarter Switzerland:  
Angst+Pfister Sensors and Power AG

Thurgauerstrasse 66  
CH-8050 Zurich  
Phone +41 44 877 35 00  
sensorsandpower@angst-pfister.com

Office Germany:  
Angst+Pfister Sensors and Power  
Deutschland GmbH  
Edisonstraße 16  
D-85716 Unterschleißheim  
Phone +49 89 374 288 87 0  
sensorsandpower.de@angst-pfister.com



## We are here for you. Addresses and Contacts.

### Sales Germany & Austria

Geometrical sensors  
Other products

Kurt Stritzelberger  
Phone +49 89 374 288 87 22  
kurt.stritzelberger@angst-pfister.com

Pressure sensors  
Other products

Gerhard Vetter  
Phone +49 89 374 288 87 26  
gerhard.vetter@angst-pfister.com

Gas sensors and modules

Peter Felder  
Phone +41 44 877 35 05  
peter.felder@angst-pfister.com

### Sales Switzerland & Liechtenstein

Postcode 3000 – 9999

Basil Frei  
Phone +41 44 877 35 18  
basil.frei@angst-pfister.com

Postcode 1000 – 2999

Christian Mohrenstecher  
Phone +41 76 444 57 93  
christian.mohrenstecher@angst-pfister.com

### Sales International Key Accounts

Peter Felder  
Phone +41 44 877 35 05  
peter.felder@angst-pfister.com

### Sales Other Countries / Product Management

Pressure Sensors  
Load Cells

Philipp Kistler  
Phone +41 44 877 35 03  
philipp.kistler@angst-pfister.com

Gas sensors  
Gas sensor modules

Dr. Thomas Clausen  
Phone +49 89 374 288 87 24  
thomas.clausen@angst-pfister.com

Flow / Level / Medical products

Dr. Adriano Pittarelli  
Phone +49 89 374 288 87 67  
adriano.pittarelli@angst-pfister.com

Power supplies

Sebastiano Leggio  
Phone +41 44 877 35 06  
sebastiano.leggio@angst-pfister.com

Linear position sensors  
Angle sensors

Eric Letsch  
Phone +41 44 877 35 14  
eric.letsch@angst-pfister.com

Accelerometers  
Sensor elements

Christoph Kleye  
Phone +49 89 374 288 87 61  
christoph.kleye@angst-pfister.com

Drive technology  
CH Postcode 5000 – 9999 / DE

Roman Homa  
Phone +41 76 444 00 86  
roman.homa@angst-pfister.com

Drive technology  
CH Postcode 1000 – 4999 / AT / IT / FR

Christian Mohrenstecher  
Phone +41 76 444 57 93  
christian.mohrenstecher@angst-pfister.com

Harald Thomas  
Phone +49 89 374 288 87 23  
harald.thomas@angst-pfister.com