

DP-51PW6

50MHz DIFFERENTIAL PROBE

USER'S MANUAL

This probe is in compliance with IEC-61010-031 CAT I or CAT II, Pollution Degree 2.

1. Safety Terms and Symbols

Terms appear in this manual:



WARNING. Warning statements identify conditions or practice that could result in injury or loss life.



CAUTION. Caution statements identify conditions or practice that could result in damage to this product or other property.

Symbols appear on the product:



Danger
High Voltage



Protective
(Earth) Terminal



Attention
Refer to Manual

2. General Safety Summary

Review the following safety precautions to avoid injury and prevent damage to this probe or any products that connected to it.

Observe maximum working voltage

To avoid any injury, do not use the probe under following conditions, the voltage between either input lead and earth is above 600Vrms CAT II

Must be grounded

This probe is grounded with the shell of BNC connector and an auxiliary grounding terminal, through the grounding conductor of the power cord of the measurement instrument.

Before making connections to the input leads of this probe, ensure that the output BNC connector is attached to the BNC connector of the measurement instrument and the auxiliary grounding terminal is connected to a proper ground, while the measurement instrument is properly grounded.

Use fused test prods if necessary

If this probe is intended to use for measurements in circuits of INSTALLATION CATEGORY III, it should incorporate with fused test prods.

Do not operate without covers

To avoid electric shock or fire hazard, do not operate this probe with covers removed.

Do not operate in wet/damp conditions

To avoid electric shock, do not operate this probe in wet or damp conditions.

Do not operate in explosive atmosphere

To avoid injury or fire hazard, do not operate this probe in an explosive atmosphere.

Avoid exposed circuit

To avoid injury, remove jewelry such as rings, watches, and other metallic objects. Do not touch exposed connections and components when power is present.

Use proper power source

To ensure this probe function well, use four AA cells or 6VDC/90mA or regulated 9VDC/70mA mains adaptor or power lead.

Do not operate with suspected failures

If you suspect there is damage to this probe, have it inspected by qualified service personnel.

3. Description

By enabling conventional oscilloscopes to display and measure in-circuit waveforms that are referenced to high common mode voltages, the differential probe extends the measurement capability of oscilloscopes in electronic power converters, inverters, motor speed controls, switch mode power supplies, and many other applications.

4. Installation

- a. Simply plug-in the BNC output connector to the vertical input of a general purposed oscilloscope or other measurement instrument, and connects the auxiliary grounding terminal to a proper ground. The measurement instrument must have a ground referenced.
- b. Connect an appropriate power source (mains adaptor, battery pack or power lead) to this probe and then turn it on.



WARNING. To protect against electric shock, use only the accessories supplied with this probe.

- c. Using the appropriate probe accessories, connect the inputs to the circuits under measurement.



CAUTION. This probe is to carry out differential measurement between two points on the circuit under measurement. This probe is not for electrically insulating the circuit under measurement and the measuring instrument.

5. Appearance

The differential probe looks as follows.

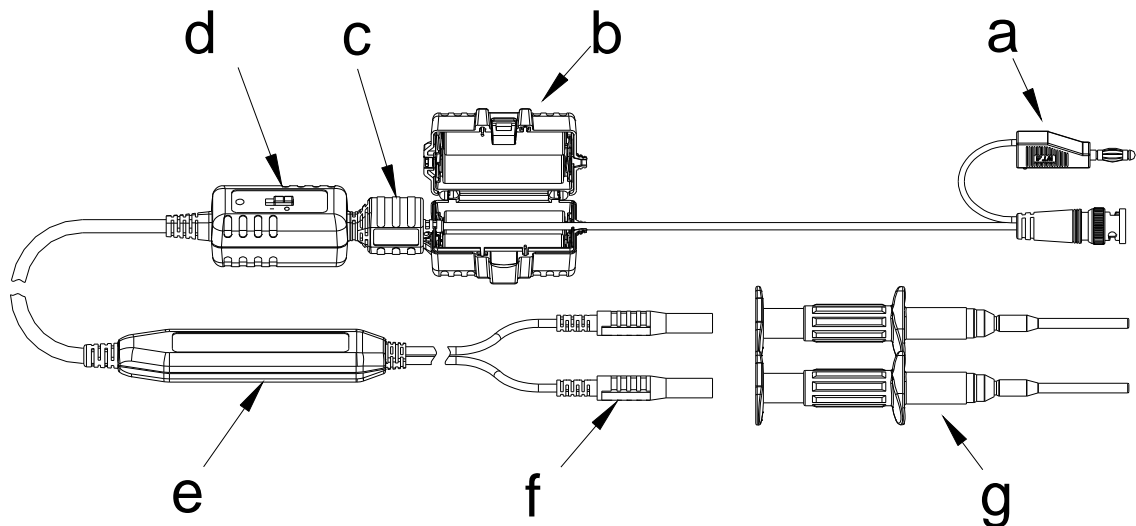

- a. Output Cable: The BNC output connector and an auxiliary grounding terminal are connected to the oscilloscope.
- b. Removable Battery Pack (optional): 4 x AA cells
- c. Power Source Connector:
This connector can be connected to the following sources;
 - Mains adaptor (6VDC/90mA or regulated 9VDC/70mA)
 - Removable battery pack (4 x AA cells)
 - Power leads
- d. Power Supply
- e. Probe Body
- f. The input leads of the differential probe
- g. Sprung Hooks: The sprung hooks are connected safely to test points in circuits.

6. Power Leads

Two types of power leads are offered;

- a. Lemo[®] Lead: For the oscilloscope whose power connector is Lemo[®] connector.
- b. Probus[®] Lead: For the oscilloscope whose power connector is Probus[®] connector.

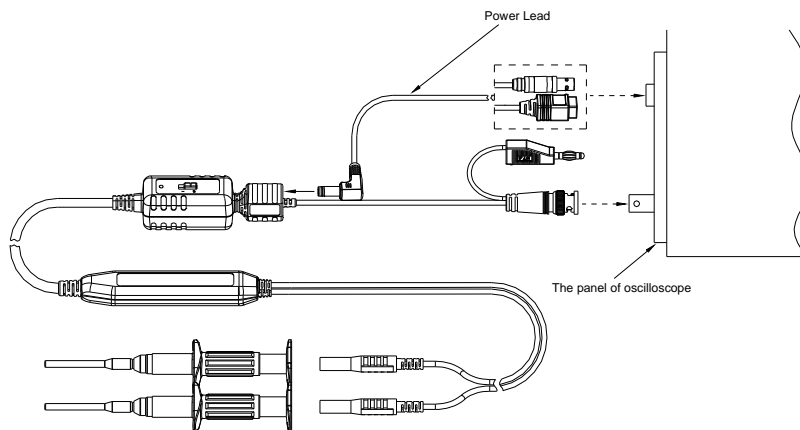

7. Removable Battery Pack

The following figure illustrates the operation of the removable battery pack;

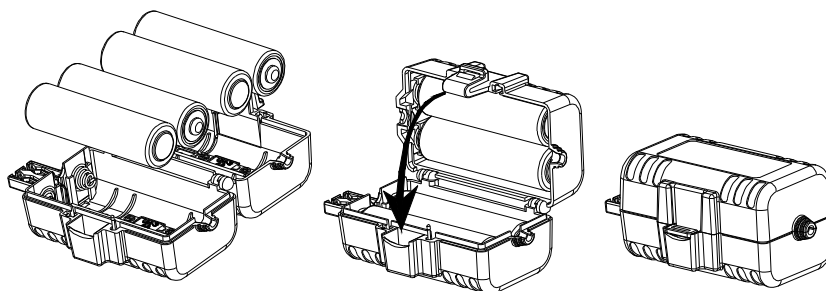

8. Specifications

Bandwidth	DC to 50MHz (-3dB)
Attenuation Ratio	1/100
Accuracy	±1%
Rise Time	<7ns
Input Impedance	4MΩ//7pF each side to ground
Input Voltage*	
- Differential Range	±700V(DC+Peak AC) or 600Vrms
- Common Mode Range	±1400V(DC+Peak AC) or 600Vrms
- Absolute Max. Voltage (either input to ground)	±1400V(DC+Peak AC) or 600Vrms CAT II
Output	
- Swing (into 5kΩ load)	±7V
- Offset (typical)	<±1mV
- Noise (typical)	0.3mVrms
- Source Impedance (typical)	50Ω (for using 1MΩ input system oscilloscope)
CMRR (typical)	-90dB @60Hz, -55dB @1MHz
Power Requirements**	Mains adaptor (6VDC/90mA or 9VDC/70mA)
(Three options of power sources)	Removable battery pack (4xAA cells) Power leads
Optional Extension plugs for mains adaptor	
- Input	One jack of 1A current rating.
- Output	Three plugs of 1A current rating.
Ambient Operating Temperature	-10 to 40°C
Ambient Storage Temperature	-30 to 70°C
Ambient Operating Humidity	25 to 85% RH
Ambient Storage Humidity	25 to 85% RH
Length of BNC Cable	125cm
Length of Input Leads	50cm
Weight	300gms
Dimensions (LxWxH)	111mm x 22mm x 14mm

* Voltage limit is the lesser of the DC+Peak AC and RMS values..

- **
- The supplied voltage must be less than 16V and greater than 3.3V, otherwise the probe could be damaged or can't be operated properly.
 - For wrong polarity of power sources, a built-in circuit will protect the probe and no danger or damage will occur.
 - When the voltage of the cells become too low, the power indicator on the panel will dim and then distinguish.

8. Derating Curve

The derating curve of the absolute maximum input voltages (either input to ground) is illustrated as follows;

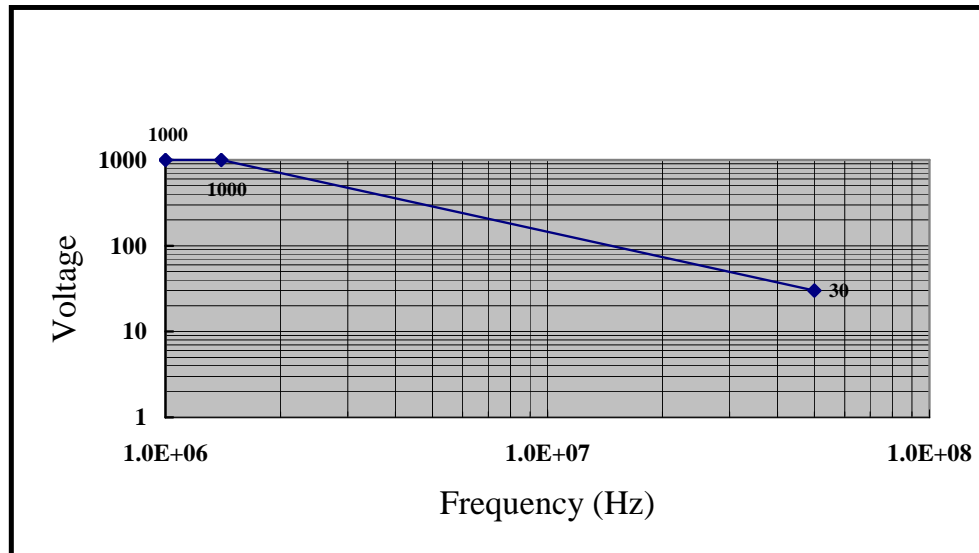

9. Inspection Procedure

- Connect the BNC output connector to the vertical input of a general purposed oscilloscope.
- Connect an appropriate power source to this probe and then turn it on.
- Set the oscilloscope to DC coupling and 1V/div. Center the trace on the display.
- Connect the inputs of the probe to power lines.
- Then, a 50Hz/60Hz sine-wave of proper amplitude will be displayed on the screen of the oscilloscope and this means the probe is working properly.

10. Cleaning

Use a soft cloth to clean the dirt. Prevent damage to probe.

- Avoid immersing the probe.
- Avoid using abrasive cleaners.
- Avoid using chemicals contains benzene or similar solvents.

Lemo® and Probus® are the registered trademarks

Date: June 1,2004

Headquarter Switzerland:
Angst+Pfister Sensors and Power AG

Thurgauerstrasse 66
CH-8050 Zurich
Phone +41 44 877 35 00
sensorsandpower@angst-pfister.com

Office Germany:
Angst+Pfister Sensors and Power
Deutschland GmbH
Edisonstraße 16
D-85716 Unterschleißheim
Phone +49 89 374 288 87 0
sensorsandpower.de@angst-pfister.com



We are here for you. Addresses and Contacts.

Sales Germany & Austria

Geometrical sensors
Other products

Kurt Stritzelberger
Phone +49 89 374 288 87 22
kurt.stritzelberger@angst-pfister.com

Pressure sensors
Other products

Gerhard Vetter
Phone +49 89 374 288 87 26
gerhard.vetter@angst-pfister.com

Gas sensors and modules

Peter Felder
Phone +41 44 877 35 05
peter.felder@angst-pfister.com

Sales Switzerland & Liechtenstein

Postcode 3000 – 9999

Basil Frei
Phone +41 44 877 35 18
basil.frei@angst-pfister.com

Postcode 1000 – 2999

Christian Mohrenstecher
Phone +41 76 444 57 93
christian.mohrenstecher@angst-pfister.com

Sales International Key Accounts

Peter Felder
Phone +41 44 877 35 05
peter.felder@angst-pfister.com

Sales Other Countries / Product Management

Pressure Sensors
Load Cells

Philipp Kistler
Phone +41 44 877 35 03
philipp.kistler@angst-pfister.com

Gas sensors
Gas sensor modules

Dr. Thomas Clausen
Phone +49 89 374 288 87 24
thomas.clausen@angst-pfister.com

Flow / Level / Medical products

Dr. Adriano Pittarelli
Phone +49 89 374 288 87 67
adriano.pittarelli@angst-pfister.com

Power supplies

Sebastiano Leggio
Phone +41 44 877 35 06
sebastiano.leggio@angst-pfister.com

Linear position sensors
Angle sensors

Eric Letsch
Phone +41 44 877 35 14
eric.letsch@angst-pfister.com

Accelerometers
Sensor elements

Christoph Kleye
Phone +49 89 374 288 87 61
christoph.kleye@angst-pfister.com

Drive technology
CH Postcode 5000 – 9999 / DE

Roman Homa
Phone +41 76 444 00 86
roman.homa@angst-pfister.com

Drive technology
CH Postcode 1000 – 4999 / AT / IT / FR

Christian Mohrenstecher
Phone +41 76 444 57 93
christian.mohrenstecher@angst-pfister.com

Harald Thomas
Phone +49 89 374 288 87 23
harald.thomas@angst-pfister.com