



VQ21T Series Combustible Gas Sensor Elements

To be read in conjunction with "Introduction to Pellistor Gas Sensors" and Pellistor Application Notes 1, 2, 3, 4, 6 and 7.

FEATURES

- Poison resistant
- Low voltage
- For fixed systems

INTRODUCTION

SGX Sensortech supplies a wide range of combustible gas sensors (pellistors) working on the catalytic oxidation principle. The VQ21T Series are members of the VQ21 range of high power, low voltage poison resistant detectors for general purpose applications, particularly for fixed point systems where the consideration of power consumption is not an overriding factor. It may be used to detect most flammable gases and vapours and, in particular, can detect methane in air mixtures with concentrations from 0.1% up to 5% (100%LEL).

SGX Sensortech made several major improvements to the structure of pellistor beads to reduce the susceptibility to catalyst poisoning which was a major failing of early pellistor structures. The structure of the VQ21 range represents the most poison resistant one available from any source. The VQ21T Series is particularly resistant to poisoning by the most serious poisons, the whole range of silicones. The VQ21T Series will provide several orders of magnitude longer life when compared with a standard VQ1 pellistor. A typical response of a VQ21T sensor when exposed to hexamethyldisiloxane vapour is shown on page 3.

PRINCIPLE OF OPERATION

The detector consists of a fine coil of platinum wire embedded in a porous ceramic bead impregnated with a noble metal catalyst. The coil acts as an electrical heater and as a resistance thermometer. The bead is mounted on a header with connecting leads and is surrounded by a metal can with the end open to the atmosphere. If a flammable gas is present when the bead is heated to about 400 °C - 500 °C the gas will oxidise and the resultant release of energy will heat the bead still further. This increase in temperature is detected as an increase in resistance of the coil.

The temperature of the coil is also affected by ambient temperature and by variations in thermal conductivity of the air caused by the possible presence of non-flammable gases such as carbon dioxide. To compensate for temperature changes not caused by the oxidation of the flammable gas a second, inert bead is used. This compensator consists of a ceramic bead made on a similar platinum coil and instead of containing a catalyst the ceramic surface is treated so that oxidation cannot take place. The two beads, generally mounted on separate headers, are then used in a circuit which detects the difference

in their resistances. Since the two beads are generally of a different colour, they have different emissivities and hence different slope resistances. Therefore, to obtain the best temperature performance it is necessary to connect a suitable fixed resistor in parallel with the compensator to correct for its higher slope resistance.

SGX Sensortech pellistors are supplied as a set of detector and compensator elements together with a resistor, all three having been carefully matched together to obtain the best performance.

Operation

The output of a sensor is dependent on a complex combustion process established around the sensing beads. It is imperative that the layers of gas around the beads are not disturbed, otherwise the bead temperature and hence device output will change. Therefore the devices must be mounted in a draught-free environment. Ideally, the elements should be mounted symmetrically side by side with the open ends exposed to the gas being monitored. The elements are supplied with 'O' rings so that gas-tight seals may be made between the elements and the mounting. As for all sensors operating on the catalytic oxidation principle, the sensor should be separated from the gas being monitored by a suitable flame arrester.

It is recommended that the detector and compensator be run in a Wheatstone Bridge circuit so that a difference signal may be obtained. A suitable circuit is shown on page 2.

In use, the bridge supply voltage should not be allowed to vary by more than the specified 0.1 V, or the output in clean air may change in sympathy.

Although SGX Sensortech generally recommends that pellistors should be run with a constant voltage supply to the bridge, it is possible to use a constant current supply to the bridge provided that the voltage across the bridge in clean air remains within the recommended limits.

GENERAL DATA

This information relates to the device operating continuously in the recommended bridge circuit and mounted in a standard SGX Sensortech test block, details of which are available on request.

Gases detected	most flammable gases and vapours
Bridge supply voltage	2.0 ± 0.1 V
Sensor current	300 mA typical
Sensor power consumption	750 mW max
Minimum sensitivity (see note 1)	15 mV/%
Linearity	linear up to 3% methane
Response time (t ₅₀) (see note 2)	2 s typical
Maximum gas concentration (see note 3)	100% LEL
Shock test (see note 4)	250 g, 5 blows in each plane
Vibration test (see note 4)	20 g, 24 cycles from 100 to 3200 Hz

RECOMMENDED BRIDGE CIRCUIT

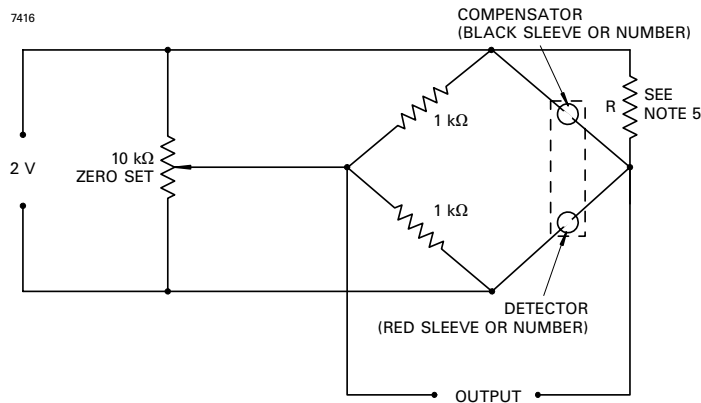

MARKING

Each pair of elements carries a unique serial number. For devices supplied with PCB legs the number is written in red on the side of the detector can and in black on the compensator can. For devices with flexible legs, the numbers on are sleeves on the legs. The letter code is on a red sleeve on one detector leg and on a black sleeve on the compensator. The numerical part of the number is on the other leg in standard resistor colour code.

PRECAUTIONS

Do not apply more than 50% of the maximum bridge voltage to either element or otherwise there may be adverse effects on the stability of sensitivity and zero offset.

Although the VQ21T Series possesses a high degree of resistance to poisons, it will be affected by prolonged exposure. Additional protection may be provided by the use of activated carbon cloth filters, but users should be aware that, firstly, these filters will prevent high molecular weight flammable gases from reaching the detector, and, secondly, these filters require regular replacement to maintain their effectiveness.

WARNING

To ensure safe operation and to satisfy the requirements of the recognised approval authorities, e2v technologies recommends that a suitable sintered metal flame arrester be used with the device.

NOTES

1. The sensitivity is partially influenced by the flow of gas to the elements. Consequently, it is affected by the geometry of the mounting arrangements. The quoted figures were obtained in **SGX Sensortech's** standard test block, details of which are available on request.
2. The response time t_{50} is defined as the as the time for the sensor to reach 50% of final signal level. The response time is dependent on the type of mounting used and therefore it may differ in use from the quoted values.
3. If the sensor has been exposed to greater than 100% LEL gas (while powered up), the instrument's calibration should be checked. Operating the sensor in such high gas concentrations can cause the deposition of carbon on the detector, with a consequent change in sensitivity and zero offset. Running the device in clean air for an extended period will usually restore normal operation.

4. Shock and vibration test results are dependent on customer mounting conditions and application.
5. The elements are supplied as a matched pair with a selected trimming resistor R. This resistor must be fitted in parallel with the compensator as shown.

VARIANTS AND ORDERING INFORMATION

The VQ21T Series is available with a number of options. These are:

Standard 13/0.2 mm flexible leads

Solid 0.5 mm leads for PCB mounting.

Modified for superior performance in the presence of hydrogen or other very reactive gases.

The variants are identified by adding suffices added to the basic type number

When ordering, the full type number with suffices must be used.

Type Number	OPTIONS INCLUDED		
	Flexible leads	PCB legs	Hydrogen mods.
VQ21T	●		
VQ21TB		●	
VQ21TS	●		●
VQ21TSB		●	●

Other variants are available. Potential users are encouraged to discuss their applications in confidence with e2v technologies' sales and application engineers who will be able to suggest the most appropriate and economical solution to their particular requirements.

TYPICAL RESPONSE OF VQ21T AND VQ1 WHEN EXPOSED TO HEXAMETHYLDISILOXANE ATMOSPHERES

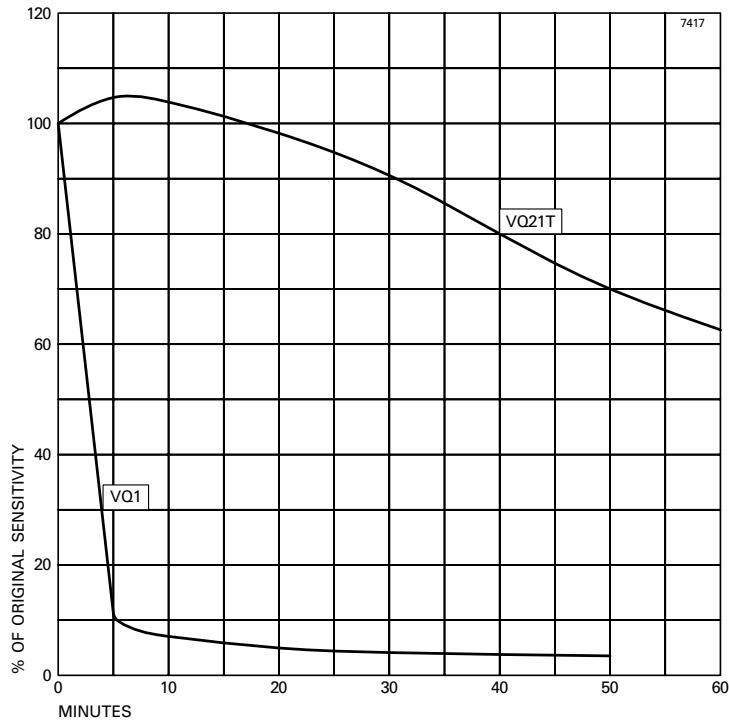

OUTLINE OF VQ21T AND VQ21TS (All dimensions without limits are nominal)

2311B

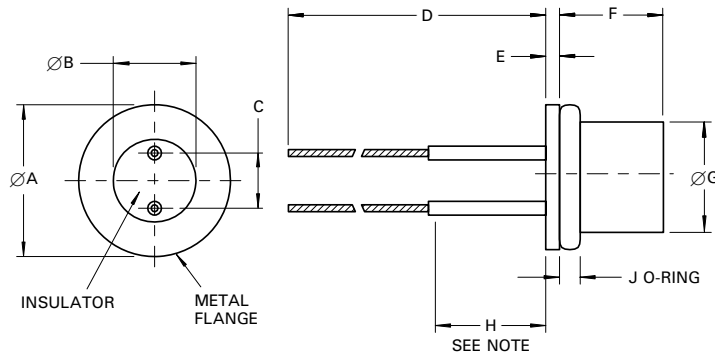

Ref	Inches	Millimetres
A	0.435 ± 0.010	11.05 ± 0.25
B	0.240 ± 0.010	6.10 ± 0.25
C	0.140 ± 0.005	3.56 ± 0.13
D	2.500 min	63.5 min
E	0.040	1.02
F	0.290 ± 0.020	7.37 ± 0.51
G	0.323 max	8.20 max
H	0.375	9.53
J	0.060	1.52

Millimetre dimensions have been derived from inches.

Note No bends may be made in this length.

OUTLINE OF VQ21TB AND VQ21TSB

7218

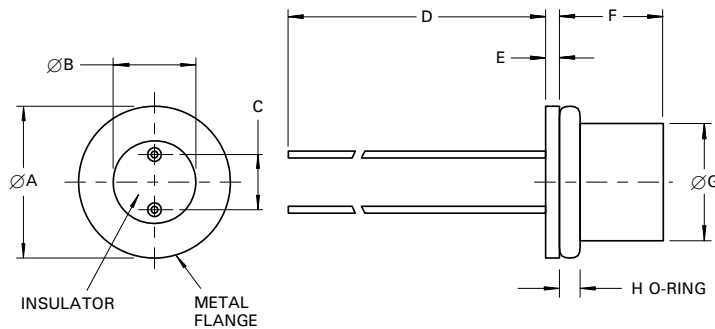

Ref	Millimetres	Inches
A	11.3 max 10.8 min	0.445 max 0.425 min
B	6.35 max 5.85 min	0.250 max 0.230 min
C	3.69 max 3.43 min	0.145 max 0.135 min
D	40.0 min	1.575 min
E	1.0 nom	0.039 nom
F	7.88 max 6.86 min	0.310 max 0.270 min
G	8.2 max	0.323 max
H	1.5 nom	0.059 nom

Inch dimensions have been derived from millimetres.

Headquarter Switzerland:
Angst+Pfister Sensors and Power AG

Thurgauerstrasse 66
CH-8050 Zurich
Phone +41 44 877 35 00
sensorsandpower@angst-pfister.com

Office Germany:
Angst+Pfister Sensors and Power
Deutschland GmbH
Edisonstraße 16
D-85716 Unterschleißheim
Phone +49 89 374 288 87 0
sensorsandpower.de@angst-pfister.com



We are here for you. Addresses and Contacts.

Sales Germany & Austria

Geometrical sensors
Other products

Kurt Stritzelberger
Phone +49 89 374 288 87 22
kurt.stritzelberger@angst-pfister.com

Pressure sensors
Other products

Gerhard Vetter
Phone +49 89 374 288 87 26
gerhard.vetter@angst-pfister.com

Gas sensors and modules

Peter Felder
Phone +41 44 877 35 05
peter.felder@angst-pfister.com

Sales Switzerland & Liechtenstein

Postcode 3000 – 9999

Basil Frei
Phone +41 44 877 35 18
basil.frei@angst-pfister.com

Postcode 1000 – 2999

Christian Mohrenstecher
Phone +41 76 444 57 93
christian.mohrenstecher@angst-pfister.com

Sales International Key Accounts

Peter Felder
Phone +41 44 877 35 05
peter.felder@angst-pfister.com

Sales Other Countries / Product Management

Pressure Sensors
Load Cells

Philipp Kistler
Phone +41 44 877 35 03
philipp.kistler@angst-pfister.com

Gas sensors
Gas sensor modules

Dr. Thomas Clausen
Phone +49 89 374 288 87 24
thomas.clausen@angst-pfister.com

Flow / Level / Medical products

Dr. Adriano Pittarelli
Phone +49 89 374 288 87 67
adriano.pittarelli@angst-pfister.com

Power supplies

Sebastiano Leggio
Phone +41 44 877 35 06
sebastiano.leggio@angst-pfister.com

Linear position sensors
Angle sensors

Eric Letsch
Phone +41 44 877 35 14
eric.letsch@angst-pfister.com

Accelerometers
Sensor elements

Christoph Kleye
Phone +49 89 374 288 87 61
christoph.kleye@angst-pfister.com

Drive technology
CH Postcode 5000 – 9999 / DE

Roman Homa
Phone +41 76 444 00 86
roman.homa@angst-pfister.com

Drive technology
CH Postcode 1000 – 4999 / AT / IT / FR

Christian Mohrenstecher
Phone +41 76 444 57 93
christian.mohrenstecher@angst-pfister.com

Harald Thomas
Phone +49 89 374 288 87 23
harald.thomas@angst-pfister.com