

AN06

Digital Output Description for SPI Pressure Sensors

This Application Note applies to the following Smate pressure sensors:

- > CCD 54D
- > CCD 53D
- > STX 13D
- > MCD 70D

Abstract:

This application note describes in detail the digital output format of smart digital pressure sensors with SPI output.

Design considerations as well as hints for writing interface firmware with an MCU are given

After reading this application note the user should be able to:

- Be able to issue commands to initiate a pressure measurement and read out the result
- Calculate the transfer function for his/her respective sensor

Foreword

The smart pressure transducers represent the next generation in digital pressure sensing. Designed to be Microcontroller friendly and optimized for battery powered operation. Among the key features:

- SPI interface with master MCU
- Sleep mode with **2 μ A** standby current
- Peak operating current of **2mA**
- Low voltage operation from **2.7V** to 5.5V and as low as **2.4V** with de-rated accuracy.

SPI Parameters

Parameters	Min	Typ	Max	Unit	Remarks
SCLK Clock Frequency (4 MHz clock)	50		800	kHz	f_{SCL}
SCLK Clock Frequency (1 MHz clock)	50		200	kHz	f_{SCL}
SS drop to first clock edge	2.5			μs	t_{HDSS}
Minimum SCLK clock Low width ¹	0.6			μs	t_{LOW}
Minimum SCLK clock High width ¹	0.6			μs	t_{HIGH}
Clock edge to data transition	0		0.1	μs	t_{CLKD}
Rise of SS relative to last clock edge	0.1			μs	t_{SUSS}
Bus free time between rise and fall of SS	0.1			μs	t_{SUDAT}

Notes

1. Combine low and high widths must equal or exceed minimum SCLK period

SPI Bus Data Output Timing

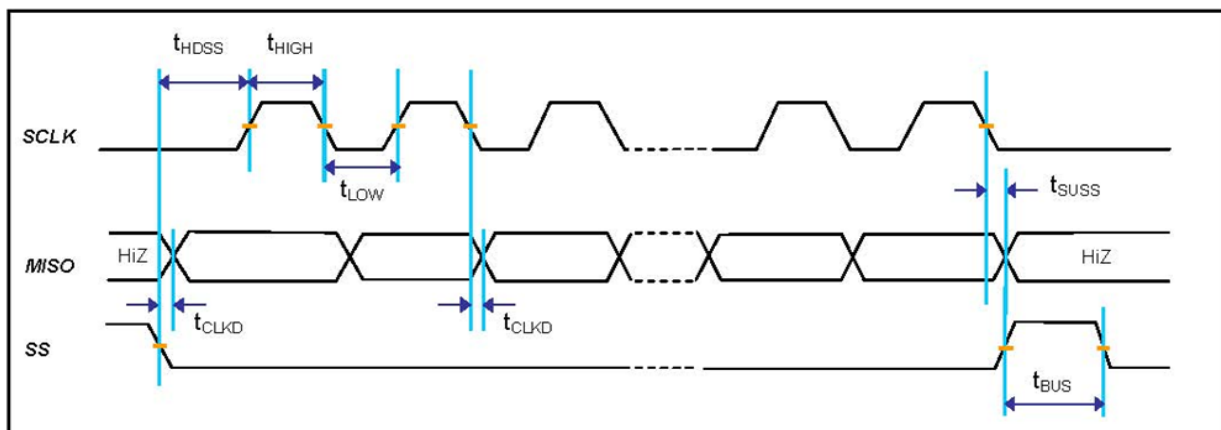

SPI Read_DF (Data Fetch)

For simplifying explanations and illustrations, only the falling edge SPI polarity will be discussed in the following sections. The SPI interface will have data change after the falling edge of SCLK. The master should sample MISO on the rise of SCLK. The entire output packet is 4 bytes (32 bits). The high of pressure data byte comes first, followed by the low of pressure data byte.

For option of pressure+ temperature, then 11 bits of corrected temperature (T[10:0]) are sent: first the T[10:3] byte and then the {T[2:0],xxxx} byte. The last 5 bits of the final byte are undetermined and should be masked off in the application. For defaulted option only requires the corrected pressure value, the read will be terminated after the 2nd byte.

SPI Output Packet with Falling Edge SPI_Polarity

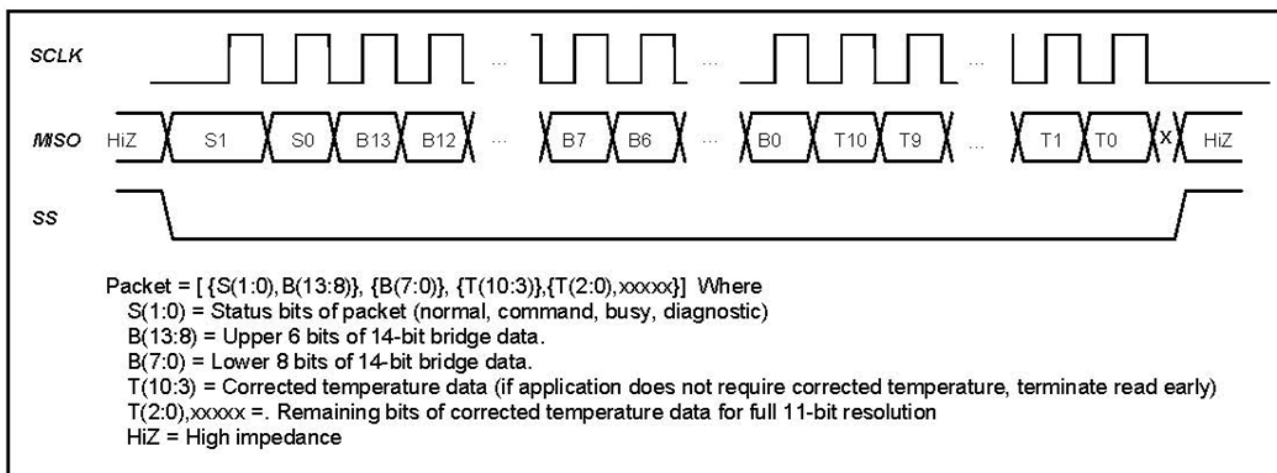

Working Mode Sleep

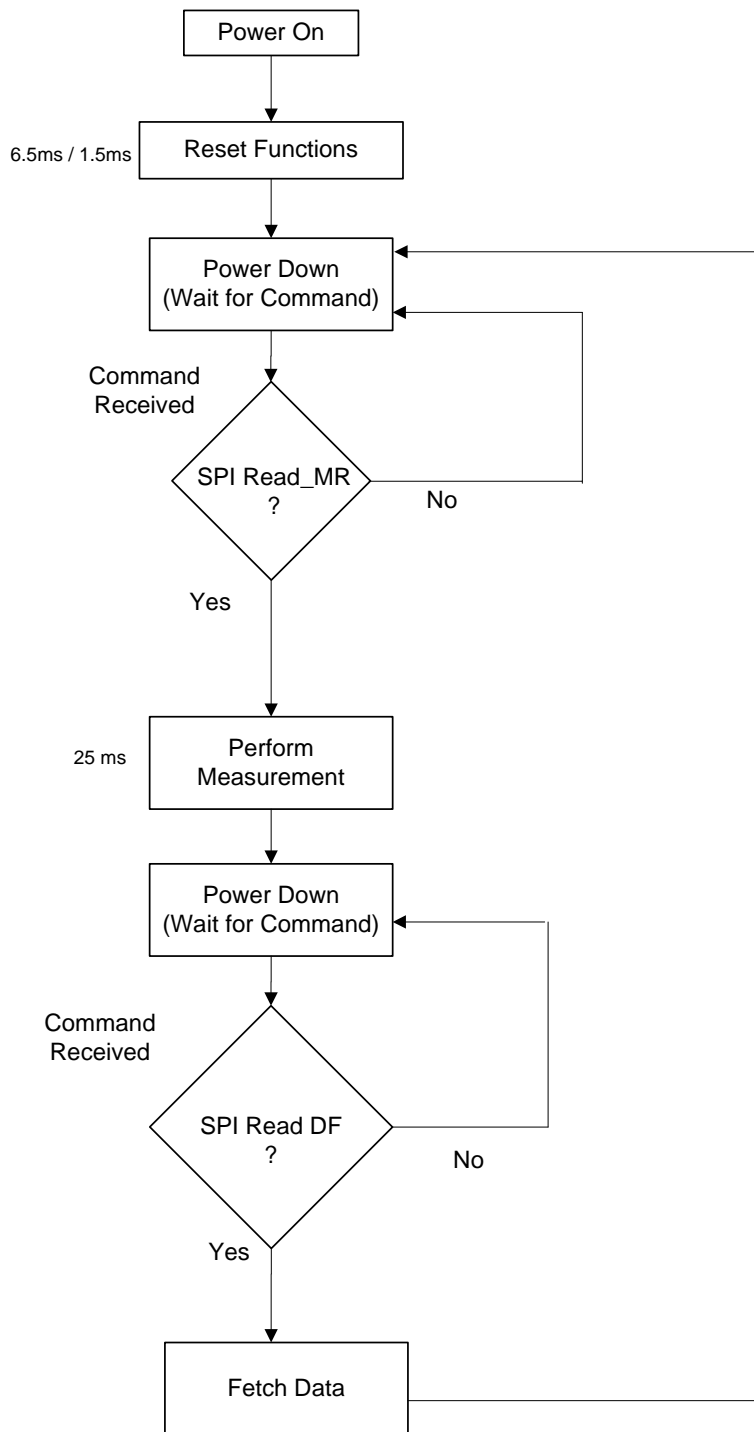

How to Interpret the Pressure/Temperature Value

All Smate digital pressure sensors have been calibrated to a straight line transfer function. Temperature and non-linearity compensation are already included and are transparent to the user. The pressure value can be easily obtained by inserting the output into the transfer function. The process is explained below.

The pressure value is read out as a 14 bit word. The word corresponds to 0x0000 to 0x3FFF in Hex or 0 to 16383 in Decimal.

The first step is to convert the Hex value to Decimal. The calculator supplied with Microsoft Windows will easily do this.

The next step is to port the decimal value into the straight line function shown in the chart below.

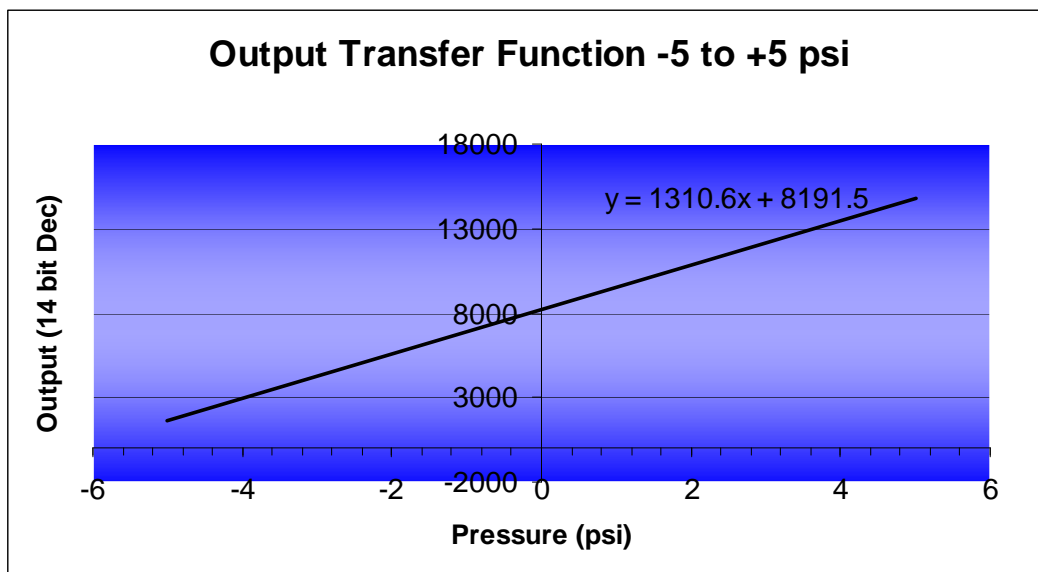

The following example is for a -5 to +5 psi transfer function:

The output word is 0x1ABC.

The output word is translated into decimal which is 6844

The decimal word is then inserted into the equation which gives:

$6844 = 1310.6x + 8191.5$ where x is the pressure in psi

We then compute $x = -1.028$ psi

Note: The transfer function varies for each pressure range. Make sure you use the correct function. The transfer functions for standard ranges are found on the next page

Transfer Function

To obtain the transfer function we start with the two parameters found in the sensor datasheet shown again below for convenience.

Parameters	Min	Typ	Max	Unit
Zero Output		0666		Hex
Full Scale Output		3996		Hex

Zero output = 0x0666 and Full Scale output = 0x3996.

The total output resolution is 14 bits or 0x3FFF.

We convert these into decimal for convenience:

Zero output = 1638, Full Scale output = 14742 and Total output resolution = 16383

Note that 1638 is 10% of total resolution and 14742 is 90% of total resolution so only 80% of the total 14 bit resolution is used to represent the required FS.

Now we correlate the outputs to the pressure range (see ordering guide in datasheet on how to specify pressure range). The example below refers to the output function on the previous page.

Parameter	Corresponding Pressure	Hex	Decimal
Zero Output	-5 psi	0x0666	1638
Full Scale Output	+ 5 psi	0x3996	14742

So taking the coordinates (-5 psi , 1638 counts) and (+5 psi, 14742 counts) we can calculate the corresponding straight line transfer function by calculating the gradient and Y-axis intercept.

In this case it is $Y = 1310.6X + 8191.5$ where Y=Digital output in Decimal and X= pressure in psi

Temperature Transfer Function:

Temperature Range	Transfer Function
-50 to 150 °C	$y = 1.275x + 63.75$ (8 bit (MSB) version)
-50 to 150 °C	$y = 10.24x + 512$ (11 bit version)

Note: The temperature transfer function is the same regardless of the pressure range chosen. The temperature output is not intended for high accuracy measurements but is instead an additional function provided at no extra cost.

Effective Resolution

While the resolution is stated as 14 bits in the datasheet it is impossible to attain this resolution in practice.

14 bits is merely the resolution of the internal Analog to Digital converter (ADC) of the ASIC used to achieve the digital compensation and output.

In practice its resolution will be lower than 14 bits with quantization noise and amplification errors that result in a non-perfect match of the input range of the ADC to the sensor being compensated.

Therefore the guaranteed resolution of Sensormate sensors is 0.05% FS or 11 bits.

In most cases the software designed to read the pressure word should (where possible) allow for an averaging of 2-8 readings. The exact resolution versus sampling speed should be determined by the customer as it is very much dependent on the application.

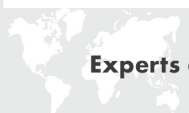

Working Mode Update

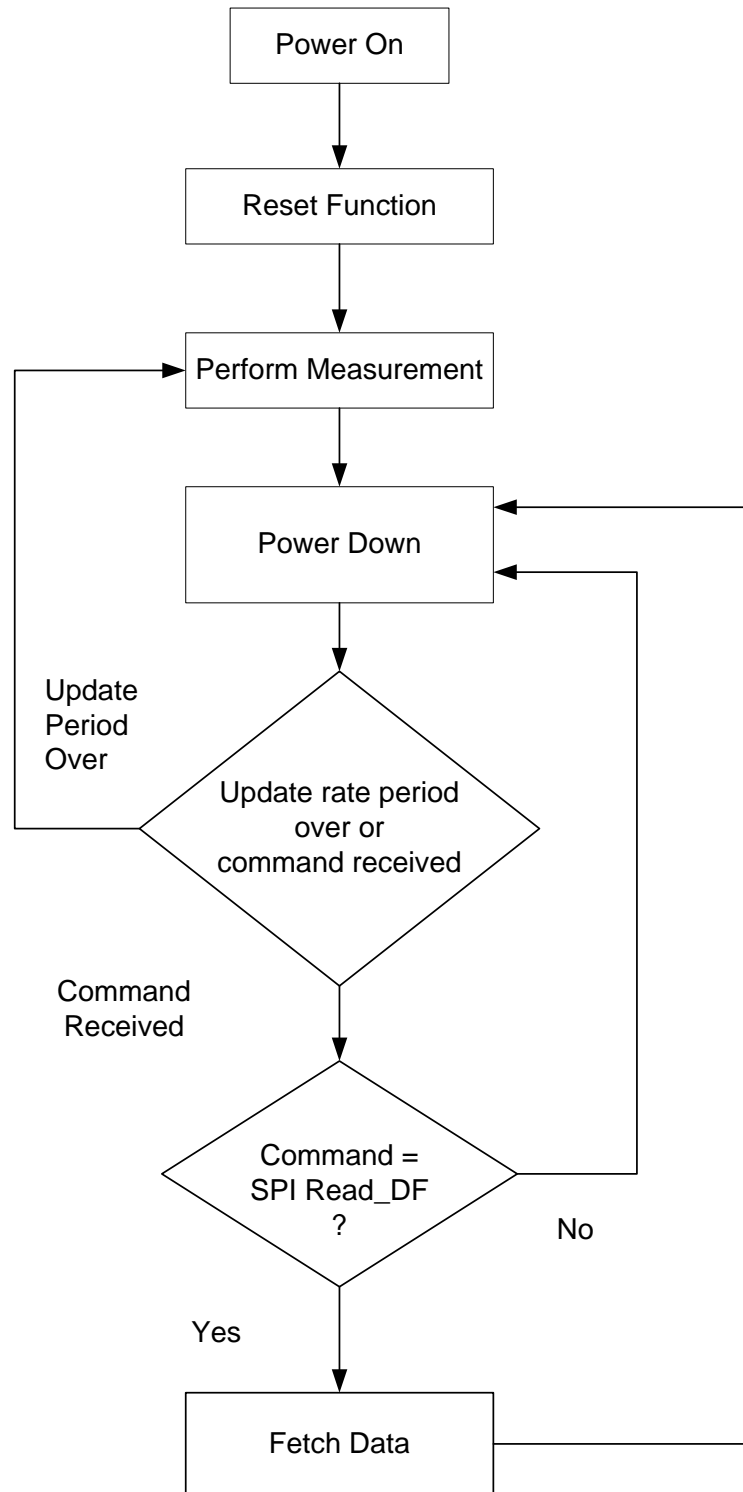

Headquarter Switzerland:
Angst+Pfister Sensors and Power AG

Thurgauerstrasse 66
CH-8050 Zurich
Phone +41 44 877 35 00
sensorsandpower@angst-pfister.com

Office Germany:
Angst+Pfister Sensors and Power
Deutschland GmbH
Edisonstraße 16
D-85716 Unterschleißheim
Phone +49 89 374 288 87 0
sensorsandpower.de@angst-pfister.com



We are here for you. Addresses and Contacts.

Sales Germany & Austria

Geometrical sensors
Other products

Kurt Stritzelberger
Phone +49 89 374 288 87 22
kurt.stritzelberger@angst-pfister.com

Pressure sensors
Other products

Gerhard Vetter
Phone +49 89 374 288 87 26
gerhard.vetter@angst-pfister.com

Gas sensors and modules

Peter Felder
Phone +41 44 877 35 05
peter.felder@angst-pfister.com

Sales Switzerland & Liechtenstein

Postcode 3000 – 9999

Basil Frei
Phone +41 44 877 35 18
basil.frei@angst-pfister.com

Postcode 1000 – 2999

Christian Mohrenstecher
Phone +41 76 444 57 93
christian.mohrenstecher@angst-pfister.com

Sales International Key Accounts

Peter Felder
Phone +41 44 877 35 05
peter.felder@angst-pfister.com

Sales Other Countries / Product Management

Pressure Sensors
Load Cells

Philipp Kistler
Phone +41 44 877 35 03
philipp.kistler@angst-pfister.com

Gas sensors
Gas sensor modules

Dr. Thomas Clausen
Phone +49 89 374 288 87 24
thomas.clausen@angst-pfister.com

Flow / Level / Medical products

Dr. Adriano Pittarelli
Phone +49 89 374 288 87 67
adriano.pittarelli@angst-pfister.com

Power supplies

Sebastiano Leggio
Phone +41 44 877 35 06
sebastiano.leggio@angst-pfister.com

Linear position sensors
Angle sensors

Eric Letsch
Phone +41 44 877 35 14
eric.letsch@angst-pfister.com

Accelerometers
Sensor elements

Christoph Kleye
Phone +49 89 374 288 87 61
christoph.kleye@angst-pfister.com

Drive technology
CH Postcode 5000 – 9999 / DE

Roman Homa
Phone +41 76 444 00 86
roman.homa@angst-pfister.com

Drive technology
CH Postcode 1000 – 4999 / AT / IT / FR

Christian Mohrenstecher
Phone +41 76 444 57 93
christian.mohrenstecher@angst-pfister.com

Harald Thomas
Phone +49 89 374 288 87 23
harald.thomas@angst-pfister.com