



DATE January 9, 2020

No. V-70284-E

Messrs. _____

SPECIFICATION

Semiconductor Pressure Sensor

Model: AL4 series (Differential Pressure Type)

Project: _____

Distributor: _____

Reference: _____

A handwritten signature in black ink, appearing to read 'Y. Uchiumi', is written over a horizontal line.

Yoshiyuki Uchiumi, Application Engineer
Sensor Business Unit
Electronic Component Business Company
Fujikura Ltd.

Fujikura Ltd.

Table of Contents

- 1. General.....2
- 2. Principle2
- 3. Device Lineup.....2
- 4. RoHS.....2
- 5. Block Diagram and Pin Connections.....3
- 6. Device Name Code4
- 7. Absolute Maximum Ratings4
- 8. Environmental Specifications.....4
- 9. Pressure Specifications5
- 10. Electrical Characteristics6
- 11. Electrical Characteristics for I²C or SPI Interface.....7
- 12. I²C or SPI Circuits (Reference)7
- 13. I²C Digital Interface8
- 14. I²C Communication Protocol.....8
- 15. SPI Digital Interface.....9
- 16. SPI Communication Protocol.....9
- 17. Output versus Input Pressure10
- 18. Transfer Function10
- 19. Device Marking11
- 20. Soldering11
- 21. Dimensions and Weights.....11
- 22. Ordering Information.....12
- 23. Tape & Reel Information12
- 24. Handling Notes.....12
- 25. Notes.....12
- Appendix: Dimension Drawing13
 - 9-772-006 ALxxDB13

Table shown below is revision records of this specification

Est.	Date	Name	Comment	Mark
	Jan. 9, 2020	Y. Uchiumi	Issued	

AL4 series (Differential Pressure Type) | V-70284-E

1. General

This document describes the specifications of the AL4 pressure sensors for differential pressure type.

2. Principle

Fujikura pressure sensor is composed of a silicon piezo-resistive pressure sensing chip and a signal conditioning integrated circuit. The low-level signal from the sensing chip is amplified, temperature compensated, calibrated, and finally converted to digital data that is proportional to the applied pressure.

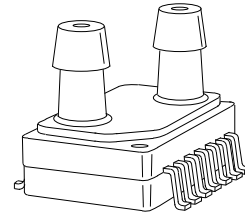

3. Device Lineup

This device has the following lineup.

Model	Pressure Type	Supply Voltage	Accuracy	Pressure Range													
				-10 (-100)	-7 (-70)	-4 (-40)	-2 (-20)	-1 (-10)	0	+1 (+10)	+2 (+20)	+4 (+40)	+7 (+70)	+10 kPa (+100 cmH ₂ O)			
AL4	Differential	5.0 Vdc 3.3 Vdc 3.0 Vdc	±1.5%FS						001KD								
									002KD								
									004KD								
									007KD								
									010KD								

Features

- ✓ Digital output
- ✓ Low pressure
- ✓ High proof pressure
- ✓ Moisture sensitivity level (MSL) 1
- ✓ Low power consumption
- ✓ High accuracy
- ✓ Modification available

Applications

- ✓ Battery-operated devices
- ✓ Medical devices
- ✓ Industrial pneumatic devices
- ✓ Consumer devices

4. RoHS

This device is compliant with the Restriction of the use of certain Hazardous Substances in Electrical and Electronic Equipment (RoHS).

5. Block Diagram and Pin Connections

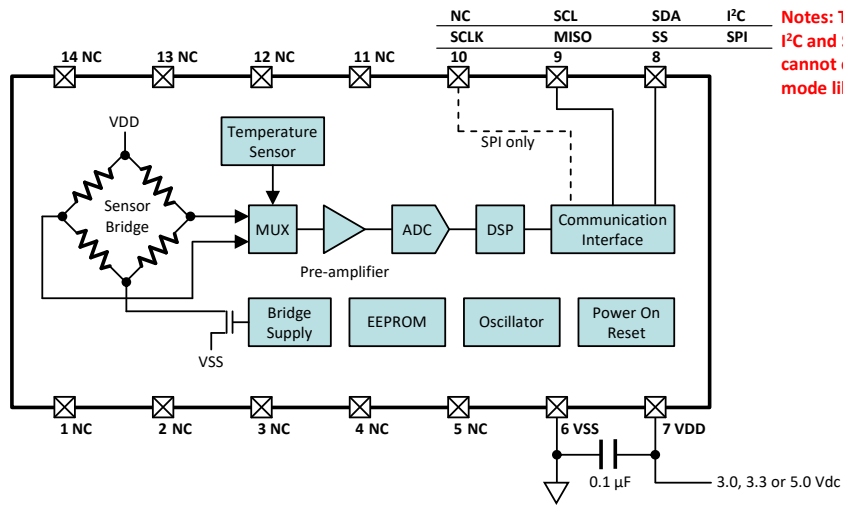

Pin Assignment	Pin No.	Pin Name	I/O	Type	Function		
	1	NC	-	-	Non-connection	*3	
	2	NC	-	-	Non-connection	*3	
	3	NC	-	-	Non-connection	*3	
	4	NC	-	-	Non-connection	*3	
	5	NC	-	-	Non-connection	*3	
	6	VSS	-	-	Common voltage connection	*1	
	7	VDD	-	-	Power supply connection	*1	
	8	I ² C SDA SPI SS	SDA SS	I/O I	Digital Digital	Serial bidirectional data Slave select	*2
	9	I ² C SCL SPI MISO	SCL MISO	I O	Digital Digital	Serial clock input Master-In-Slave-Out	*2
	10	I ² C SCLK SPI SCLK	NC SCLK	- I	- Digital	Non-connection Serial clock input	*2
	11	NC	-	-	-	Non-connection	*3
	12	NC	-	-	-	Non-connection	*3
	13	NC	-	-	-	Non-connection	*3
	14	NC	-	-	-	Non-connection	*3

Notes:

- *1) Put a 0.1µF capacitor between VDD Pin 7 and VSS.
- *2) I²C or SPI is factory setting. User cannot change communication mode.
- *3) NC pins must be open.

AL4 series (Differential Pressure Type) | V-70284-E

6. Device Name Code

The device name code is consisted of Sensor code, Pressure code, Slave address code and Packing. For the exact ordering device number, please refer to Chapter 22 Ordering Information.

Sensor code		Pressure code		Packing		TP: Tape & Reel	
AL4	1 DB	007K	D	2	TP	if applicable	
Custom ID						S: SPI mode	
						2: 0x28	
						3: 0x38	
						4: 0x48	
						5: 0x58	
						6: 0x68	
						7: 0x78	
Communication code						Slave address for I ² C mode	
Pressure type						D: Differential pressure	
						001KD: -1 kPa to +1 kPa	
						002KD: -2 kPa to +2 kPa	
						004KD: -4 kPa to +4 kPa	
						007KD: -7 kPa to +7 kPa	
Pressure range						010KD: -10 kPa to +10 kPa	
Port option						DB: Dual axial barbed ports 	
						0: 5.0 Vdc	
						1: 3.3 Vdc	
Supply voltage						2: 3.0 Vdc	
Model						AL4: Low pressure SMD Digital output	

Pressure Range Conversion (Reference)

Pressure Code	kPa	mbar	cmH ₂ O	inchH ₂ O	psi	mmHg
001KD	-1 - +1	-10 - +10	-10.1972 - +10.1972	-4.01865 - +4.01865	-0.145038 - +0.145038	-7.50062 - +7.50062
002KD	-2 - +2	-20 - +20	-20.3943 - +20.3943	-8.03729 - +8.03729	-0.290075 - +0.290075	-15.0012 - +15.0012
004KD	-4 - +4	-40 - +40	-40.7886 - +40.7886	-16.0746 - +16.0746	-0.580151 - +0.580151	-30.0025 - +30.0025
007KD	-7 - +7	-70 - +70	-71.3801 - +71.3801	-28.1305 - +28.1305	-1.01526 - +1.01526	-52.5043 - +52.5043
010KD	-10 - +10	-100 - +100	-101.972 - +101.972	-40.1865 - +40.1865	-1.45038 - +1.45038	-75.0062 - +75.0062

Note:

*1) The device is calibrated based on the unit of "kPa". Other converted pressure values are for reference.

7. Absolute Maximum Ratings

Item	Condition	Symbol	Rating		Unit
			Min.	Max.	
Supply Voltage		VDD _{max}	-0.3	6	Vdc
Voltage at Digital I/O pins		V _{diomax}	-0.3	VDD+0.3	Vdc
Operating Temperature		T _{opt}	-40	+85	°C
Storage Temperature		T _{stg}	-40	+85	°C

Notes:

*1) Absolute maximum ratings are the limits that the device will withstand without damage.

8. Environmental Specifications

Item	Condition	Symbol	Rating			Unit
			Min.	Typ.	Max.	
Operating Humidity	Non-condensing, +65°C		-	-	95	%RH *1, 2
Storage Humidity	Non-condensing, +65°C		-	-	95	%RH *1, 2

Notes:

*1) Do not wet the device with dew.

*2) If the device is operated or storage at above +65°C in 95%RH, accuracy of the output is subject to be out of the specifications.

9. Pressure Specifications

Type of Pressure	Differential pressure	*1
Pressure Media	Non-corrosive gases for wetted materials	*2, 3

Notes:

- *1) Differential pressure is defined as the difference between the pressure applied to Port A and that to Port B. See the figure below.
- *2) Wetted materials are PPS resin, silicone resin, silicon, gold, Cu alloy and silver.
- *3) Ensure the pressure media contains no particulates. The device is not compatible with liquids.

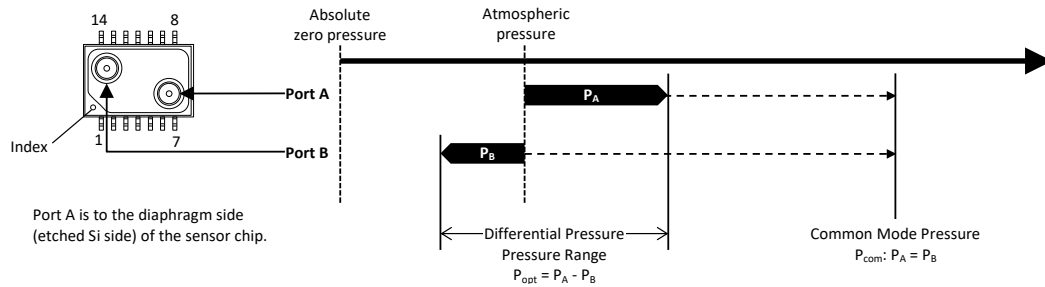

Pressure Table

Pressure Code	Item Symbol	Pressure Range *1		Proof Pressure *2	Burst Pressure *3	Common Mode Pressure *4	Unit
		Min. P_{opt}	Max. P_{opt}	P_{max}	P_{burst}	P_{com}	
001KD		-1	+1	+100	+100	+100	kPa
002KD		-2	+2	+100	+100	+100	kPa
004KD		-4	+4	+100	+100	+100	kPa
007KD		-7	+7	+100	+100	+100	kPa
010KD		-10	+10	+100	+100	+100	kPa

Notes:

- *1) In Pressure Range (P_{opt}), the output is proportional to difference between the pressure applied to Port A and Port B, meeting the specified accuracy.
- *2) Proof Pressure (P_{max}) is defined as maximum applied pressure to the device without damage.
- *3) The device will be damaged, if applied pressure is beyond Burst Pressure (P_{burst}).
- *4) Common Mode Pressure is defined as maximum applied pressure to Port A and B simultaneously.

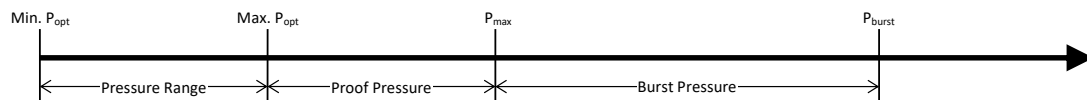

Pressure Port Connection

Recommended Tube (Reference)

Flexible tubing is recommended. The following tubing is for reference. Please select appropriate tubing considering material, Durometer hardness and maximum pressure. Manifold connection can also be available with O-ring or sealing fixtures.

Unit	I.D.	O.D.	Wall thickness
inch	3/32	7/32	1/16
mm	2	4	1

Manifold Connection (Reference)

Manifold connection can also be available with O-ring or sealing fixtures. There are parting lines on the surface of the pressure port at the base side. Top part of the pressure port (barbed part) is recommended for sealing with fixtures.

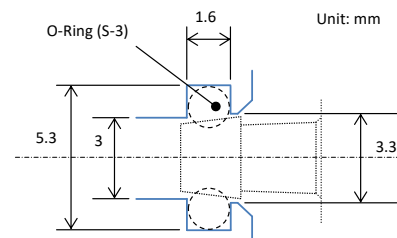

10. Electrical Characteristics

Ambient temperature $T_a=25^\circ\text{C}$

Item	Condition	Symbol	Rating			Unit	
			Min.	Typ.	Max.		
Supply Voltage	Sensor Code	VDD	AL40DB	4.75	5	5.25	Vdc *1
			AL41DB	3.135	3.3	3.465	
			AL42DB	2.85	3.0	3.15	
Offset Pressure Data	Min. P_{opt} , $P_A < P_B$	D_{off}	598	819	1040	Count *2, 3	
Balanced Pressure Data	$P_A = P_B$	D_{bal}	7971	8192	8413	*4	
Full Scale Pressure Data	Max. P_{opt} , $P_A > P_B$	D_{fs}	15344	15565	15786	Count *5	
Span Pressure Data	Min. to Max. P_{opt}	SD	-	14746	-	Count *6	
Accuracy	in Compensated Temperature	Error	-1.0	-	+1.0	%FS *7, 8, 9	
Compensated Temperature		T_c	-5	-	+65	$^\circ\text{C}$ *10	
Supply Current	VDD = 5 Vdc	I_c	-	-	4.5	mAdc *11	
	VDD = 3.3, 3.0 Vdc		-	-	3.5		
Initializing Time	After VDD reaching 2.7 V	t_{init}	-	-	10	msec. *12	
Sampling Frequency		f_{smp}	-	2	-	kHz *13	
Response Time	for reference	t_r	-	1	-	msec. *14	
Temperature Data	for reference	D_{tmp}	-5 $^\circ\text{C}$	-	461	-	Count *15
			+25 $^\circ\text{C}$	-	768	-	
			+65 $^\circ\text{C}$	-	1177	-	
Dielectric Strength			-	-	1	mA *16	
Insulation Resistance			100	-	-	MΩ *17	

Notes:

- *1) Supply voltage (VDD) should be constant.
- *2) Offset pressure data (D_{off}) is defined as the pressure data at minimum P_{opt} .
- *3) Balanced pressure data (D_{bal}) is defined as the pressure to Port A equals that to Port B.
- *4) Balanced pressure data error is calibration error of Balanced pressure data (D_{bal}) at production. It does not include Long term drift. It would be suggested that applications have Auto-zeroing function.
- *5) Full scale pressure data (D_{fs}) is defined as the pressure data at maximum P_{opt} .
- *6) Span pressure data (SD) is defined as the pressure data difference between Offset pressure data (D_{off}) and Full scale pressure data (D_{fs}).
- *7) The unit of Accuracy "%FS" is defined as a percent error by Span pressure data (SD).
- *8) Accuracy (Error) is the specs of out-going inspection at Fujikura. It consists of the following:
 - Non-linearity
 - Temperature errors over the temperature range -5 to 65 $^\circ\text{C}$
 - Pressure hysteresis
 - Calibration errors of sensitivity and offset
- *9) The following errors are NOT included to Accuracy (Error):
 - Offset change due to port orientation sensitivity, soldering thermal stress and assembling mechanical stress
 - Offset drift over time
- *10) Please also refer to Chapter 18 Transfer Function.
- *11) Lower power mode is available for a modification product. Please ask Fujikura.
- *12) Initializing process starts when VDD reached 2.7 V. After initializing process, ready to data read. See the figure below.
- *13) Sampling frequency is time to data ready.
- *14) Response time (t_r) is defined as the time for the change in the pressure data from 10% to 90% or from 90% to 10% of its final value when the input pressure makes a step change. See the figure below.
- *15) Temperature Data (D_{tmp}) is for reference.
- *16) Dielectric strength is defined as the leakage current between all pins and the package with AC 500 V, 1 minute.
- *17) Insulation resistance is defined as the resistance value between all pins and the package with DC 500 V.

Initializing Time

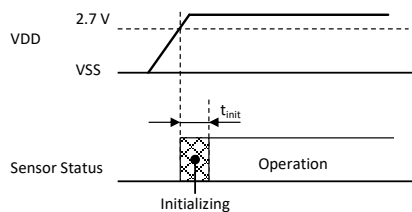

Response Time

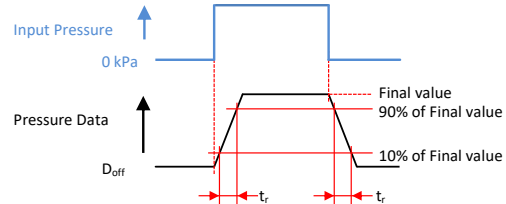

11. Electrical Characteristics for I²C or SPI Interface

Communication interface (communication mode) of I²C or SPI is factory setting. User cannot change communication mode like from I²C to SPI or from SPI to I²C.

Ambient temperature $T_a=25^{\circ}\text{C}$

Item	Condition	Symbol	Rating			Unit	
			Min.	Typ.	Max.		
Interface			I ² C or SPI			*1	
Input Low Voltage	Sensor Code	V_{IL}	AL40DB	0	-	1	V
			AL41DB	0	-	0.66	V
			AL42DB	0	-	0.6	V
Input High Voltage	Sensor Code	V_{IH}	AL40DB	4	-	5	V
			AL41DB	2.64	-	3.3	V
			AL42DB	2.4	-	3	V
Output Low Voltage	Sensor Code	V_{OL}	AL40DB	-	-	0.5	V
			AL41DB	-	-	0.33	V
			AL42DB	-	-	0.3	V

Notes:

*1) I²C is a trademark of NXP Semiconductors.

12. I²C or SPI Circuits (Reference)

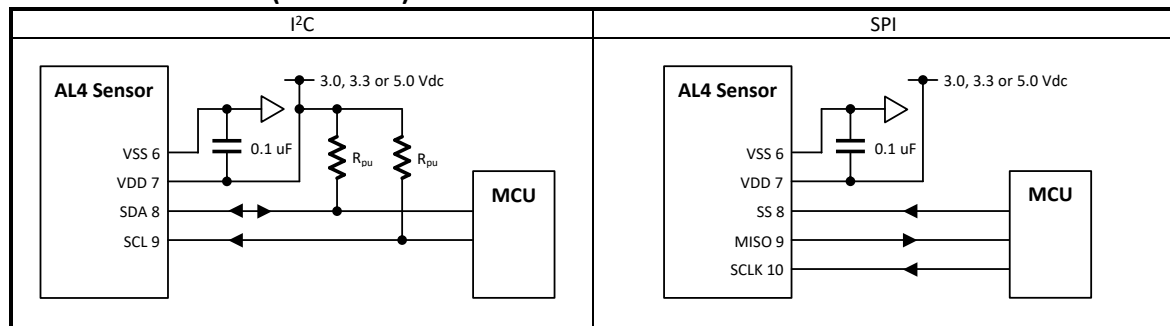

13. I²C Digital Interface

Item	Condition	Symbol	Rating			Unit
			Min.	Typ.	Max.	
SCL clock frequency		f_{SCL}	100	-	400	kHz
Start condition hold time relative to SCL edge		t_{HDSTA}	0.1	-	-	μ sec.
Minimum SCL clock low width		t_{LOW}	0.6	-	-	μ sec. *2
Minimum SCL clock high width		t_{HIGH}	0.6	-	-	μ sec. *2
Start condition setup time relative to SCL edge		t_{SUSTA}	0.1	-	-	μ sec.
Data hold time on SDA relative to SCL edge		t_{HDDAT}	0	-	-	μ sec.
Data setup time on SDA relative to SCL edge		t_{SUDAT}	0.1	-	-	μ sec.
Stop condition setup time on SCL		t_{SUSTO}	0.1	-	-	μ sec.
Bus free time between stop condition and start condition		t_{BUS}	2	-	-	μ sec.
Load Capacitance	Pin8 SDA, 400kHz	C_{max}	-	-	200	pF
Pull-up Resistor	Pin8 SDA, Pin9 SCL	R_{pu}	1	-	-	k Ω
Slave address	7 bit, Factory setting		0x28 to 0x78			*3

Notes:

- *1) There are three differences in this device protocol compared with the original I²C™ protocol:
 - Sending a start-stop condition without any transitions on the CLK line (no clock pulses in between) creates a communication error for the next communication, even if the next start condition is correct and the clock pulse is applied. An additional start condition must be sent, which results in restoration of proper communication.
 - The restart condition - a falling SDA edge during data transmission when the CLK clock line is still high - creates the same situation. The next communication fails, and an additional start condition must be sent for correct communication.
 - A falling SDA edge is not allowed between the start condition and the first rising SCL edge. If using an I²C™ address with the first bit 0, SDA must be held low from the start condition through the first bit.
- *2) Combined low and high widths must equal or exceed minimum SCLK period.
- *3) Slave address is factory setting. Customer cannot change the slave address.

Timing Diagram

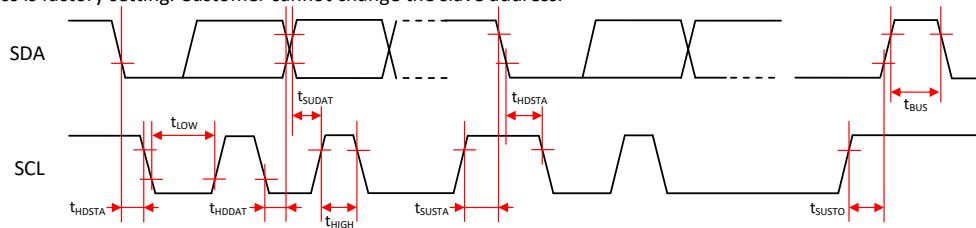

14. I²C Communication Protocol

Item	Measurement Packet	
Data Fetch		
Status bits	00	Normal operation , good data packet
	01	Device in Command Mode
	10	Stale data: Data has already been fetched since the last measurement cycle.
	11	EEPROM Error

Notes:

- *1) If the status bits are 01, the device must be re-started to turn power supply off and on again.
- *2) If a data fetch is performed before or during the first measurement after power-on reset, then “stale” will be returned, but this data is actually invalid because the first measurement has not been completed.
- *3) If the status bits are 11, do not use the device anymore.

15. SPI Digital Interface

This mode is half duplex (read-only).

Item	Condition	Symbol	Rating			Unit
			Min.	Typ.	Max.	
SCLK clock frequency	4 MHz clock	f_{SCL}	50	-	800	kHz
SS drop to first clock edge		t_{HDSS}	2.5	-	-	μ sec.
Minimum SCLK clock low width		t_{LOW}	0.6	-	-	μ sec. *1
Minimum SCLK clock high width		t_{HIGH}	0.6	-	-	μ sec. *1
Clock edge to data transition		t_{CLKD}	0	-	0.1	μ sec.
Rise of SS relative to last clock edge		t_{SUSS}	0.1	-	-	μ sec.
Buss free time between rise and fall of SS		t_{BUS}	2	-	-	μ sec.

Notes:

*1) Combined low and high widths must equal or exceed minimum SCLK period.

Timing Diagram

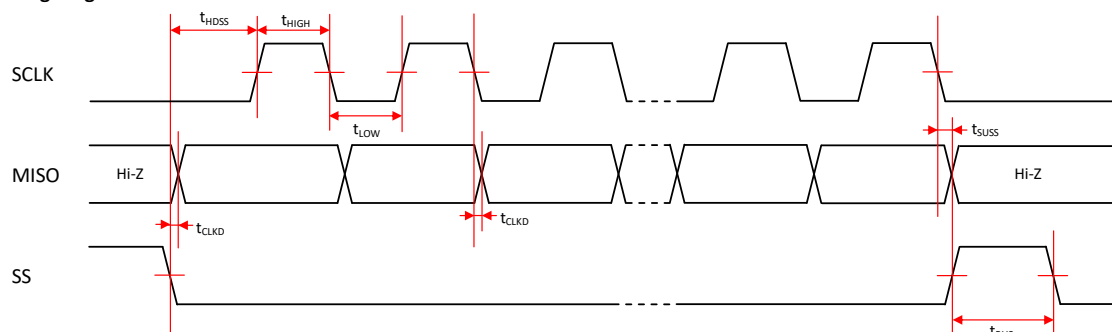

16. SPI Communication Protocol

The master should sample MISO on the rise of SCLK.

Item	Measurement Packet
Data Fetch	<p>SCLK </p> <p>MISO </p> <p>SS </p> <p>Packet = $\{S(1:0), B(13:8), \{B(7:0)\}, \{T(10:3)\}, \{T(2:0), xxxxx\}\}$ S(1:0) = Status bits of packet (Normal, Command, Busy, EEPROM Error) P(13:8) = Upper 6 bits of 14-bit pressure data P(7:0) = Lower 8 bits of 14-bit pressure data T(10:3) = Corrected temperature data (if application does not require corrected temperature data, terminate read only.) T(2:0), xxxxx = Remaining bits of corrected temperature data for full 11-bit resolution Hi-Z = High impedance</p>

17. Output versus Input Pressure

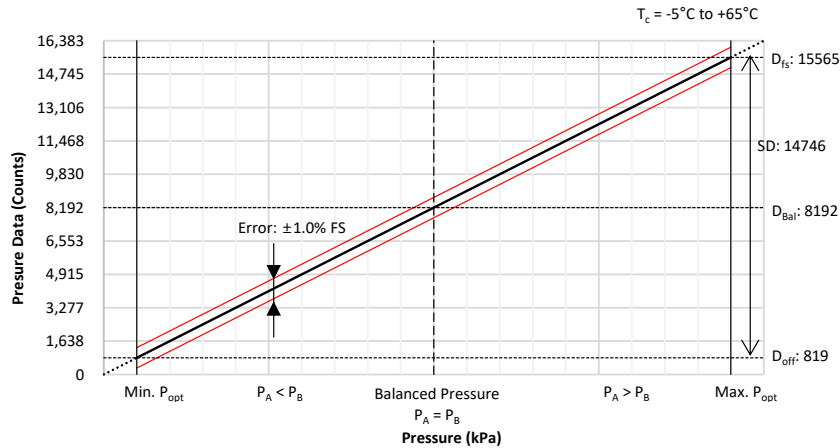

18. Transfer Function

Item	Transfer Function																														
Pressure Data	$\text{Pressure Data (Counts)} = P \times \alpha + \beta \pm (\text{Error} \times \text{Temperature Error Multiplier})$																														
	\updownarrow																														
	$P \text{ (kPa)} = \frac{\text{Pressure Data} - \beta \pm (\text{Error} \times \text{Temperature Error Multiplier})}{\alpha}$																														
	<table border="1"> <thead> <tr> <th>Pressure Code</th> <th>P (kPa)</th> <th>α</th> <th>β</th> <th>Error</th> </tr> </thead> <tbody> <tr> <td>001KD</td> <td>-1 to +1</td> <td>7373</td> <td>8192</td> <td>147</td> </tr> <tr> <td>002KD</td> <td>-2 to +2</td> <td>7373/2</td> <td>8192</td> <td>147</td> </tr> <tr> <td>004KD</td> <td>-4 to +4</td> <td>7373/4</td> <td>8192</td> <td>147</td> </tr> <tr> <td>007KD</td> <td>-7 to +7</td> <td>7373/7</td> <td>8192</td> <td>147</td> </tr> <tr> <td>010KD</td> <td>-10 to +10</td> <td>7373/10</td> <td>8192</td> <td>147</td> </tr> </tbody> </table>	Pressure Code	P (kPa)	α	β	Error	001KD	-1 to +1	7373	8192	147	002KD	-2 to +2	7373/2	8192	147	004KD	-4 to +4	7373/4	8192	147	007KD	-7 to +7	7373/7	8192	147	010KD	-10 to +10	7373/10	8192	147
Pressure Code	P (kPa)	α	β	Error																											
001KD	-1 to +1	7373	8192	147																											
002KD	-2 to +2	7373/2	8192	147																											
004KD	-4 to +4	7373/4	8192	147																											
007KD	-7 to +7	7373/7	8192	147																											
010KD	-10 to +10	7373/10	8192	147																											
Temperature Data	$D_{\text{tmp}} \text{ (Counts)} = \frac{2047}{200} \times (T + 50) \quad \longleftrightarrow \quad T \text{ (}^\circ\text{C)} = \frac{200}{2047} \times D_{\text{tmp}} - 50$																														

19. Device Marking

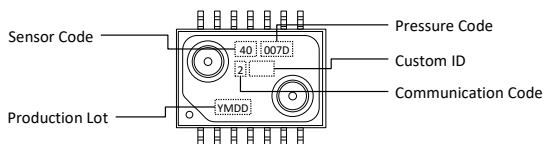

Production Lot *1	Sensor Code		Pressure Code		Communication Code		Custom ID Marking
	Marking	Marking	Marking	Marking	Marking	Marking	
Y: Last digit of year	0 to 9	AL40DB 40	001KD 001D	2	2	If applicable	
M: Month Jan. to Sep.	1 to 9	AL41DB 41	002KD 002D	3	3		
October	X	AL42DB 42	004KD 004D	4	4		
November	Y		007KD 007D	5	5		
December	Z		010KD 010D	6	6		
DD: Date	00 to 31			7	7		
				S	S		

Notes:

*1) Production Lot is 10 year cycle.

20. Soldering

Items	Condition																		
Moisture Sensitivity Level	Level 1																		
Reflow Soldering Profile	<table border="1"> <thead> <tr> <th>Stage</th> <th>Description</th> <th>Condition</th> </tr> </thead> <tbody> <tr> <td>A</td> <td>Ramp up</td> <td>2 to 4°C / sec.</td> </tr> <tr> <td>B</td> <td>Pre-heating</td> <td>150 to 180°C 60 to 120 sec.</td> </tr> <tr> <td>C</td> <td>Ramp up</td> <td>2 to 4°C / sec.</td> </tr> <tr> <td>D</td> <td>Heating</td> <td>Above 230°C, 45 sec. max. 245°C max., 10 sec. max.</td> </tr> <tr> <td>E</td> <td>Ramp down</td> <td>2 to 4°C / sec.</td> </tr> </tbody> </table>	Stage	Description	Condition	A	Ramp up	2 to 4°C / sec.	B	Pre-heating	150 to 180°C 60 to 120 sec.	C	Ramp up	2 to 4°C / sec.	D	Heating	Above 230°C, 45 sec. max. 245°C max., 10 sec. max.	E	Ramp down	2 to 4°C / sec.
Stage	Description	Condition																	
A	Ramp up	2 to 4°C / sec.																	
B	Pre-heating	150 to 180°C 60 to 120 sec.																	
C	Ramp up	2 to 4°C / sec.																	
D	Heating	Above 230°C, 45 sec. max. 245°C max., 10 sec. max.																	
E	Ramp down	2 to 4°C / sec.																	

Notes:

- *1) This device is classified as moisture sensitivity level (MSL) 1 that is defined in Jeced standard J-STD-20. Floor life time is unlimited. However, the plating of pins is silver (Ag) that could be discolored to black or brown by sulfur in the environment. Discoloration of pins could impact soldering reliability. The device should be sealed in the embossed carrier tape before soldering.
- *2) NEVER wash the device with any washing liquid. NEVER wash the device with any ultrasonic washing machine.
- *3) Do not put the solder and flux on the device's package.
- *4) Temperature means Surface temperature of the device's package.
- *5) Do not reflow more than twice.

21. Dimensions and Weights

Refer to the following drawing as attached. 3D CAD model is available. Please ask Fujikura distributor.

Sensor Code	Dimension Drawing	Weight
AL4xDB	9-772-006	approx. 0.55 grams

22. Ordering Information

Model	Package	Supply Voltage	Packing	Ordering Device Number	Qty./Packing
AL4	SMD	5.0 Vdc	Tape & Reel	AL40DB-[Pressure Code]-[Com Code]-TP	350 Pcs/Reel
		3.3 Vdc	Tape & Reel	AL41DB-[Pressure Code]-[Com Code]-TP	350 Pcs/Reel
		3.0 Vdc	Tape & Reel	AL42DB-[Pressure Code]-[Com Code]-TP	350 Pcs/Reel

Pressure Range	Pressure Code
-1 kPa to +1 kPa	001KD
-2 kPa to +2 kPa	002KD
-4 kPa to +4 kPa	004KD
-7 kPa to +7 kPa	007KD
-10 kPa to +10 kPa	010KD

		Communication Code
I ² C Slave address	0x28	2
	0x38	3
	0x48	4
	0x58	5
	0x68	6
SPI		5

I2C or SPI is factory setting.
User cannot change the communication mode.

23. Tape & Reel Information

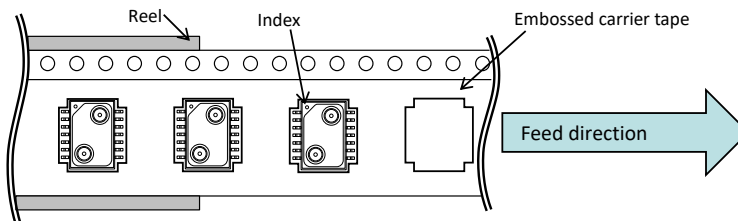

24. Handling Notes

Plating of pins is silver (Ag). Silver has physical property that is discolored to black or brown by sulfur. There are notes for handling as below:

- To prevent discoloration of pins, please keep the devices sealed in static shielding bags before soldering.
- Do not solder the devices that have discolored pins.
- After soldering, pins would be discolored in black or brown in atmosphere. However it does not impact reliability of the device.

25. Notes

- Fujikura reserves all rights.
- This document is subject to change without notice.
- Limitation, usage, environment, standard warranty and so on are listed on Fujikura web site.
- Please refer to the latest specifications.

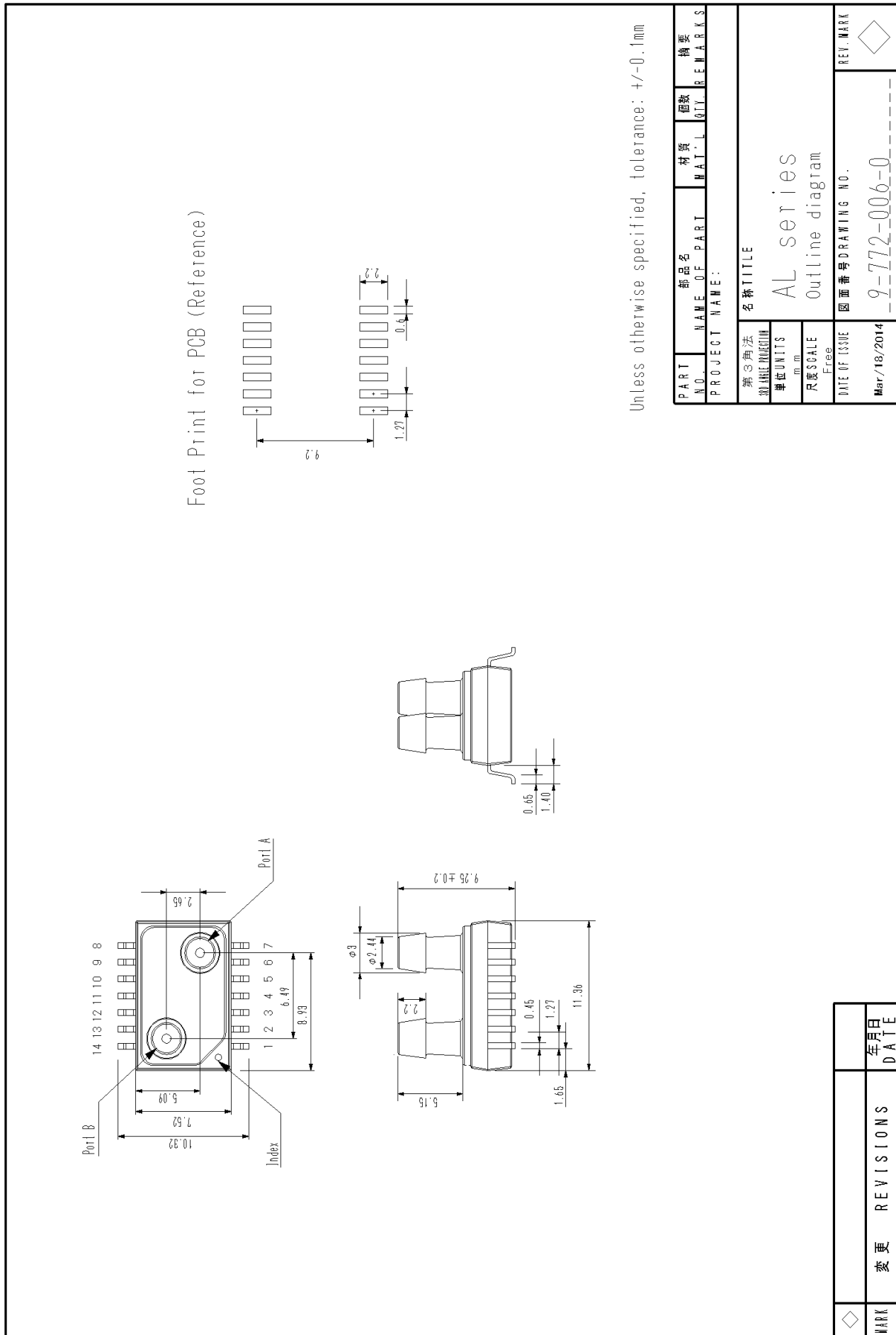

PART NO.	部品名	材質	個數	摘要
NAME OF PART	MAT.	QTY.	REMARKS	
PROJECT NAME:				
名稱 TITLE				
AL series				
Outline diagram				
第3角法 DIMENSION				
單位 UNITS	mm			
尺碼 SCALE	Free			
DATE OF ISSUE	圖面番號 DRAWING NO.			
Mar/18/2014	9-772-006-0			
	REV. MARK			
	◇			

年 月 日	DATE
更 改	REVISIONS
◇	

Headquarter Switzerland:
Angst+Pfister Sensors and Power AG

Thurgauerstrasse 66
CH-8050 Zurich
Phone +41 44 877 35 00
sensorsandpower@angst-pfister.com

Office Germany:
Angst+Pfister Sensors and Power
Deutschland GmbH
Edisonstraße 16
D-85716 Unterschleißheim
Phone +49 89 374 288 87 0
sensorsandpower.de@angst-pfister.com



We are here for you. Addresses and Contacts.

Sales Germany & Austria

Geometrical sensors
Other products

Kurt Stritzelberger
Phone +49 89 374 288 87 22
kurt.stritzelberger@angst-pfister.com

Pressure sensors
Other products

Gerhard Vetter
Phone +49 89 374 288 87 26
gerhard.vetter@angst-pfister.com

Gas sensors and modules

Peter Felder
Phone +41 44 877 35 05
peter.felder@angst-pfister.com

Sales Switzerland & Liechtenstein

Postcode 3000 – 9999

Basil Frei
Phone +41 44 877 35 18
basil.frei@angst-pfister.com

Postcode 1000 – 2999

Christian Mohrenstecher
Phone +41 76 444 57 93
christian.mohrenstecher@angst-pfister.com

Sales International Key Accounts

Peter Felder
Phone +41 44 877 35 05
peter.felder@angst-pfister.com

Sales Other Countries / Product Management

Pressure Sensors
Load Cells

Philipp Kistler
Phone +41 44 877 35 03
philipp.kistler@angst-pfister.com

Gas sensors
Gas sensor modules

Dr. Thomas Clausen
Phone +49 89 374 288 87 24
thomas.clausen@angst-pfister.com

Flow / Level / Medical products

Dr. Adriano Pittarelli
Phone +49 89 374 288 87 67
adriano.pittarelli@angst-pfister.com

Power supplies

Sebastiano Leggio
Phone +41 44 877 35 06
sebastiano.leggio@angst-pfister.com

Linear position sensors
Angle sensors

Eric Letsch
Phone +41 44 877 35 14
eric.letsch@angst-pfister.com

Accelerometers
Sensor elements

Christoph Kleye
Phone +49 89 374 288 87 61
christoph.kleye@angst-pfister.com

Drive technology
CH Postcode 5000 – 9999 / DE

Roman Homa
Phone +41 76 444 00 86
roman.homa@angst-pfister.com

Drive technology
CH Postcode 1000 – 4999 / AT / IT / FR

Christian Mohrenstecher
Phone +41 76 444 57 93
christian.mohrenstecher@angst-pfister.com

Harald Thomas
Phone +49 89 374 288 87 23
harald.thomas@angst-pfister.com