

DATE 2 July, 2018No. V-70208-E

Messrs. _____

SPECIFICATION

Semiconductor Pressure SensorModel: AG3xF-115KA

Project: _____

Distributor: _____

Reference: _____

A handwritten signature in black ink that reads 'Y. Uchiumi'.

Yoshiyuki Uchiumi, Application Engineer
Sensor Business Unit
Electronics Business Company

Fujikura Ltd.

Table of Contents

- 1. General 2
- 2. Principle 2
- 3. Device lineup 2
- 4. RoHS 2
- 5. Block Diagram and Pin Connections 3
- 6. Drop-in Replacement 3
- 7. Device Name Code 4
- 8. Absolute Maximum Ratings 4
- 9. General Specifications 4
- 10. Electrical Characteristics 5
- 11. Output Voltage versus Input Pressure 6
- 12. Transfer Function 6
- 13. Operating Sequence 7
- 14. Device Marking 7
- 15. Soldering 8
- 16. Dimensions and Weights 8
- 17. Ordering Information 8
- 18. Tape & Reel Information 9
- 19. Footprint for PCB (for Reference) 9
- 20. Handling Notes 9
- 21. Notes 9
- Appendix: Dimension Drawing 10
 - 9-772-019 AGxxF 10

Table shown below is revision records of this specification

	Date	Name	Comment	Mark
1	July 2, 2018	Y. Uchiumi	Officially issued to start volume production	
Est.	October 5, 2017	Y. Uchiumi	Preliminary issued	

1. General

This document describes the specifications of Fujikura Pressure Sensors, Type of AG3xF-115KA.

2. Principle

Fujikura Pressure Sensor is composed of a silicon piezoresistive pressure sensing chip and a signal conditioning integrated circuit. The low-level signal from the sensing chip is amplified, temperature compensated, calibrated, and finally converted to a high-level output signal that is proportional to the applied pressure.

3. Device lineup

This device has the following lineup.

Model	Pressure Type	Supply Voltage	Accuracy	Pressure Range		
				0	15	Standard atmosphere 101.325 kPa(abs.) 115 kPa(abs.)
AG3	Absolute	5.0 Vdc	±2.0 %FS			
		3.3 Vdc	±2.5 %FS			
		3.0 Vdc				

Features

- ✓ Amplified and temperature compensated smooth analog output
- ✓ Low profile flat package
- ✓ Compatible with the XFAM/X3AM integrated pressure sensors
- ✓ Customization or modification available

Applications

- ✓ Medical devices
- ✓ Industrial pneumatic devices
- ✓ Consumer devices

4. RoHS

This device is compliant with the Restriction of the use of certain Hazardous Substances in Electrical and Electronic Equipment (RoHS).

5. Block Diagram and Pin Connections

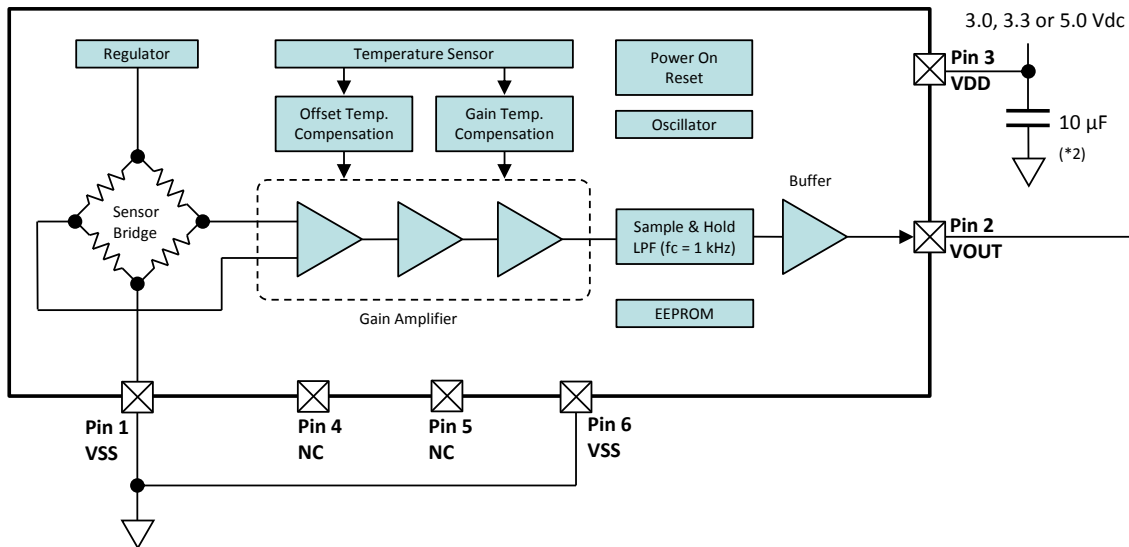

Pin Assignment	Pin No.	Pin Name	I/O	Type	Function	
	1	VSS	-	-	Common voltage connection	*1
	2	VOUT	O	Analog	Analog output	
	3	VDD	-	-	Power supply connection	*2
	4	NC	-	-	Non-connection	*3
	5	NC	-	-	Non-connection	*3
	6	VSS	-	-	Common voltage connection	*1

Notes:

- *1) Both Pin 1 and Pin 6 must be connected to VSS.
- *2) Put a 1.0 µF capacitor as minimum between Pin3 (VDD) and VSS. If VOUT is susceptible to noise, it would be recommended to increase capacitance.
- *3) Pin assignment of Pin 4 and 5 is NC (Non connection).

6. Drop-in Replacement

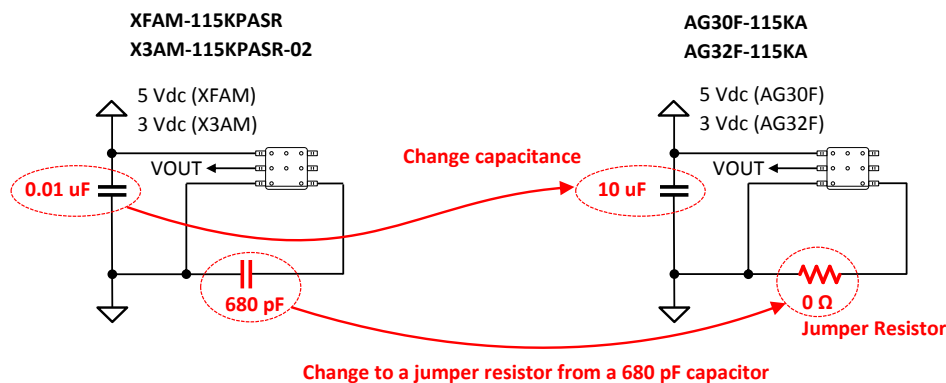

7. Device Name Code

The device name code is consisted of Sensor code, Pressure code, Custom ID and Packing style. For the exact ordering device number, please refer to Chapter 17 Ordering Information.

Sensor Code	Pressure Code	
AG3 0 F	- 115K A	- []
		Packing
		Blank: Tray TP: Tape & Reel
		Pressure type
		A: Absolute pressure
		Pressure value
		115K: 115 kPa
		Package
		F: Flat package
		0: 5.0 Vdc 1: 3.3 Vdc 2: 3.0 Vdc
		Supply voltage
		Model
		AG3: SMD / Smooth analog output

8. Absolute Maximum Ratings

Item	Symbol	Rating			Unit
		Min.	Typ.	Max.	
Load Pressure	Pmax+	-	-	+230	kPa(abs.)
Supply Voltage	VDDmax	-	-	6	Vdc
Operating Temperature	Topt	-40	-	+105	°C
Storage Temperature	Tstg	-40	-	+105	°C

Note:

- *1) Absolute maximum ratings are the limits that the device will withstand without damage.

9. General Specifications

Item	Condition	Symbol	Rating			Unit	
			Min.	Typ.	Max.		
Supply Voltage	Sensor Code	VDD	AG30F	4.75	5.0	5.25	Vdc *1
			AG31F	3.135	3.3	3.465	
			AG32F	2.85	3.0	3.15	
Type of Pressure		-	Absolute pressure			*2	
Pressure Media		-	Non-corrosive gases			*3	
Pressure Range		Popt	15	-	115	kPa(abs.) *4	
Compensated Temperature		-	0	-	+85	°C *5	
Operating Humidity	Non-condensing	Hopt	30	-	85	%RH *6	
Storage Humidity	Non-condensing	Hstg	30	-	85	%RH *6	
Dielectric Strength		-	-	-	1	mA *7	
Insulation Resistance		-	100	-	-	MΩ *8	

Notes:

- *1) Output voltage (Vout) is not perfectly ratio-metric with the power supply voltage (VDD).
- *2) Absolute pressure is defined as the difference between applied pressure to the device and absolute zero pressure.
- *3) Ensure the pressure media contains no particulates. The device is not compatible with liquids.
- *4) Pressure range is defined as the measurable pressure range of the device. Do not expose intentionally beyond minimum Popt and maximum Popt.
- *5) Please also refer to Chapter 12 Transfer Function.
- *6) Do not wet the device with dew.
- *7) Dielectric strength is defined as the leakage current between all pins and the package with AC 500, 1 minute.
- *8) Insulation resistance is defined as the resistance value between all pins and the package with DC 500 V.

10. Electrical Characteristics

Load resistor $R_L = \infty$, Ambient temperature $T_a = 25^\circ\text{C}$

Item	Condition	Symbol	Rating			Unit	
			Min.	Typ.	Max.		
Sensor Code: AG30F (VDD = 5.0 Vdc)							
Offset Voltage	Min. Popt	Voff	0.11	0.2	0.29	V	*1, 2
Full Scale Voltage	Max. Popt	Vfs	4.61	4.7	4.79	V	*3
Span Voltage	Min. to max. Popt	SV	-	4.5	-	V	*4
Accuracy	0 to 85°C	Error	-2.0	-	+2.0	%FS	*5, 6
			-0.09	-	+0.09	V	
Supply Current		Ic	-	-	6	mAdc	*7
Sensor Code: AG31F (VDD = 3.3 Vdc)							
Offset Voltage	Min. Popt	Voff	0.2325	0.3	0.3675	V	*1, 2
Full Scale Voltage	Max. Popt	Vfs	2.9325	3.0	3.0675	V	*3
Span Voltage	Min. to max. Popt	SV	-	2.7	-	V	*4
Accuracy	0 to 85°C	Error	-2.5	-	+2.5	%FS	*5, 6
			-0.0675	-	+0.0675	V	
Supply Current		Ic	-	-	5	mAdc	*7
Sensor Code: AG32F (VDD = 3.0 Vdc)							
Offset Voltage	Min. Popt	Voff	0.4625	0.5	0.5375	V	*1, 2
Full Scale Voltage	Max. Popt	Vfs	1.9625	2.0	2.0375	V	*3
Span Voltage	Min. to max. Popt	SV	-	1.5	-	V	*4
Accuracy	0 to 85°C	Error	-2.5	-	+2.5	%FS	*5, 6
			-0.0375	-	+0.0375	V	
Supply Current		Ic	-	-	5	mAdc	*7
Response Time	for reference	tr	-	1	-	msec.	*8
Load Resistor	VOUT to VSS or VDD to VOUT	RL	9.5	-	-	kΩ	*7
Load Capacitance	VOUT to VSS	CL	-	-	50	pF	*9

Notes:

- *1) Offset voltage (Voff) is defined as the output voltage at minimum Popt.
- *2) Offset error is calibration error of offset voltage at production. It does not include Long term offset drift. It would be suggested that applications have Auto-zeroing function.
- *3) Full scale voltage (Vfs) is defined as the output voltage at maximum Popt.
- *4) Output span voltage (SV) is defined as the voltage difference between Offset voltage (Voff) and Full scale voltage (Vfs).
- *5) Accuracy consists of the following:
 - Non-linearity
 - Temperature errors over the temperature range 0 to 85°C
 - Pressure hysteresis
 - Calibration errors of sensitivity and offset
- *6) The unit of Accuracy "%FS" is defined as a percent error by Span voltage (SV).
- *7) Supply Current (Ic) is increased depending on the value of Load resistor (RL).
- *8) Response time (tr) is defined as the time for the change in output voltage from 10% to 90% or from 90% to 10% of its final value when the input pressure makes a step change.

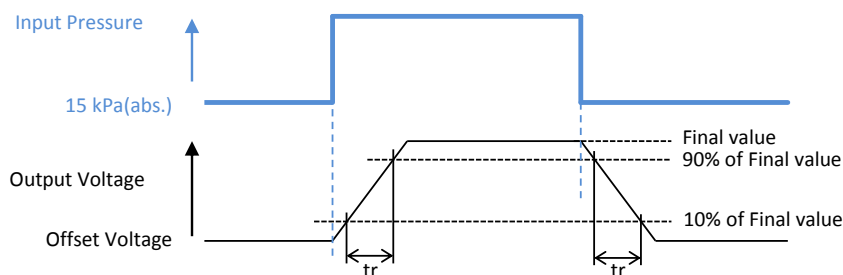

- *9) Do not put Load capacitance (CL) that is over 50 pF between VOUT and VSS.

11. Output Voltage versus Input Pressure

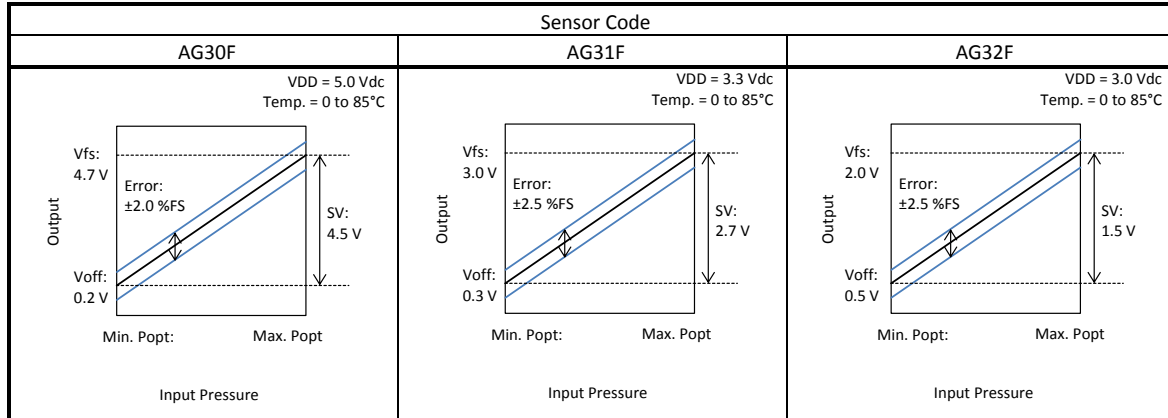

12. Transfer Function

Item	Rating																								
Transfer Function	$V_{out} (V) = VDD \times ((P \times \alpha) + \beta) \pm (\text{Pressure Error} \times \text{Temperature Error Multiplier} \times \alpha \times VDD)$ $P (kPa) = \frac{V_{out} \pm (\text{Pressure Error} \times \text{Temperature Error Multiplier} \times \alpha \times VDD) - \beta}{\alpha}$																								
Parameters	<table border="1" style="width: 100%; border-collapse: collapse;"> <thead> <tr> <th>Sensor Code</th> <th>VDD (*1)</th> <th>P</th> <th>α</th> <th>β</th> <th>Pressure Error</th> </tr> </thead> <tbody> <tr> <td>AG30F</td> <td>5.0±0.25 V</td> <td>15 to 115 kPa</td> <td>9/1000</td> <td>-19/200</td> <td>2.0 kPa</td> </tr> <tr> <td>AG31F</td> <td>3.3±0.165 V</td> <td>15 to 115 kPa</td> <td>9/1100</td> <td>-7/220</td> <td>2.5 kPa</td> </tr> <tr> <td>AG32F</td> <td>3.0±0.15 V</td> <td>15 to 115 kPa</td> <td>1/200</td> <td>11/120</td> <td>2.5 kPa</td> </tr> </tbody> </table>	Sensor Code	VDD (*1)	P	α	β	Pressure Error	AG30F	5.0±0.25 V	15 to 115 kPa	9/1000	-19/200	2.0 kPa	AG31F	3.3±0.165 V	15 to 115 kPa	9/1100	-7/220	2.5 kPa	AG32F	3.0±0.15 V	15 to 115 kPa	1/200	11/120	2.5 kPa
Sensor Code	VDD (*1)	P	α	β	Pressure Error																				
AG30F	5.0±0.25 V	15 to 115 kPa	9/1000	-19/200	2.0 kPa																				
AG31F	3.3±0.165 V	15 to 115 kPa	9/1100	-7/220	2.5 kPa																				
AG32F	3.0±0.15 V	15 to 115 kPa	1/200	11/120	2.5 kPa																				
Temperature Error Multiplier																									

Note:

*1) Output voltage (Vout) is not perfectly ratio-metric with the power supply voltage (VDD).

13. Operating Sequence

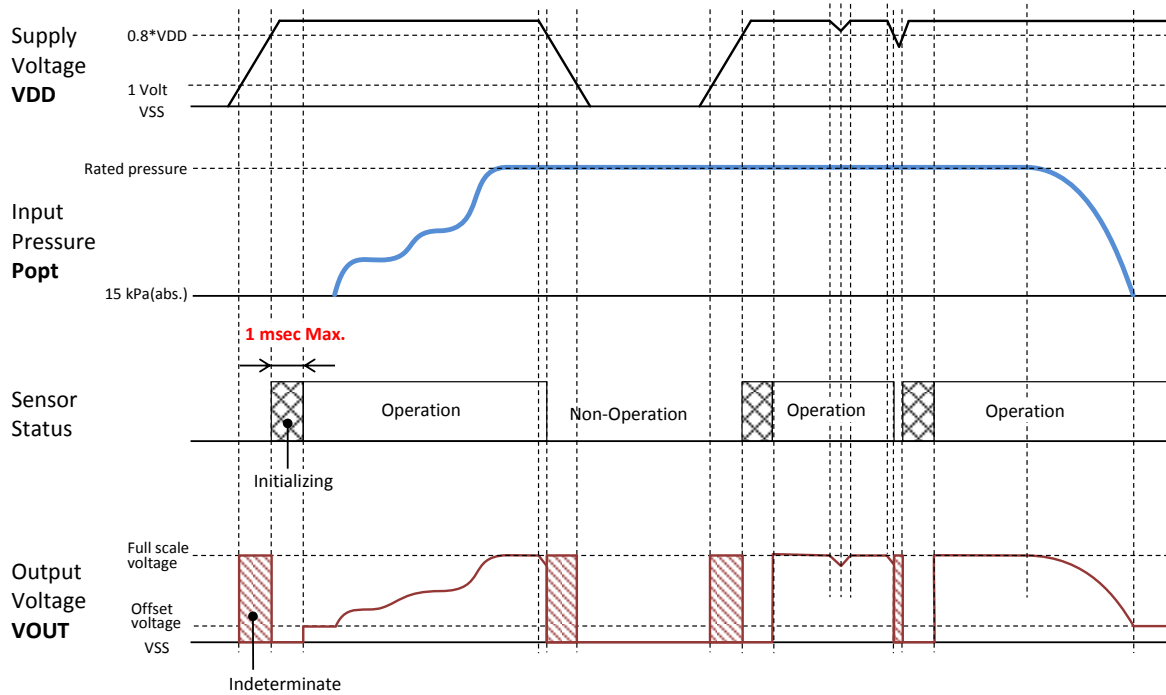

Notes:

- *1) The status of VOUT is indeterminate when supply voltage is under 0.8*VDD.
- *2) Initializing process is started when supply voltage reaches 0.8*VDD,. At initializing process, VOUT is fixed 0.1*VDD and under.

14. Device Marking

Items		Marking					
	Production Lot	0 to 9					
	Y	Last digit of Production year					
	M	Production month					
		Jan	Feb	Mar	Apr	May	Jun
		1	2	3	4	5	6
	Jul	Aug	Sep	Oct	Nov	Dec	
7	8	9	X	Y	Z		
DD	Production date						
Sensor Code		01 to 31					
AG30F		AG30					
AG31F		AG31					
AG32F		AG32					
Pressure Code		115A					

Note:

- *1) Package code is not marked on the face plate.

15. Soldering

Process	Sensor Code	Condition															
Reflow soldering	AG3xx	<div style="text-align: center;"> Soldering Profile </div>															
		<table border="1"> <tr> <td>A</td> <td>Ramp up</td> <td>2 to 4 °C / sec.</td> </tr> <tr> <td>B</td> <td>Pre-heating</td> <td>150 to 180 °C 60 to 120 sec.</td> </tr> <tr> <td>C</td> <td>Ramp up</td> <td>2 to 4 °C / sec.</td> </tr> <tr> <td>D</td> <td>Heating</td> <td>Above 230 °C, 45 sec. max. 245 °C max., 10 sec. max.</td> </tr> <tr> <td>E</td> <td>Ramp down</td> <td>2 to 4 °C / sec.</td> </tr> </table>	A	Ramp up	2 to 4 °C / sec.	B	Pre-heating	150 to 180 °C 60 to 120 sec.	C	Ramp up	2 to 4 °C / sec.	D	Heating	Above 230 °C, 45 sec. max. 245 °C max., 10 sec. max.	E	Ramp down	2 to 4 °C / sec.
		A	Ramp up	2 to 4 °C / sec.													
		B	Pre-heating	150 to 180 °C 60 to 120 sec.													
		C	Ramp up	2 to 4 °C / sec.													
		D	Heating	Above 230 °C, 45 sec. max. 245 °C max., 10 sec. max.													
E	Ramp down	2 to 4 °C / sec.															
Moisture Sensitivity Level	AG3xx	Level 1															

Notes:

- *1) NEVER wash the device with any washing liquid. NEVER wash the device with any ultrasonic washing machine.
- *2) Do not put the solder and flux on the device's package.
- *3) Temperature means the surface temperature of the device's package.
- *4) Do not reflow more than twice.
- *5) This device is classified as moisture sensitivity level (MSL) 1 that is defined in Jedec standard J-STD-20. Floor life time is unlimited. However, the plating of pins is silver (Ag) that could be discolored to black or brown by sulfur in the environment. Discoloration of pins could impact soldering reliability. The device should be sealed in the embossed carrier tape before soldering.

16. Dimensions and Weights

Refer to the following drawing as attached.

Sensor Code	Dimension Drawing	Weights
AG3xF	9-772-019	approx. 0.3 grams

17. Ordering Information

Supply Voltage	XFAM/X3AM	Ordering Device Number (Replacement Device Number)	Packing	Qty./Packing
5.0 Vdc	XFAM-115KPASR	AG30F-115KA	Tray	100 Pcs/Tray
	XFAM-115KPASR-TP	AG30F-115KA-TP	Tape & Reel	1000 Pcs/Reel
3.3 Vdc	-	AG31F-115KA	Tray	100 Pcs/Tray
	-	AG31F-115KA-TP	Tape & Reel	1000 Pcs/Reel
3.0 Vdc	X3AM-115KPASR	AG32F-115KA	Tray	100 Pcs/Tray
	X3AM-115KPASR-TP	AG32F-115KA-TP	Tape & Reel	1000 Pcs/Reel

18. Tape & Reel Information

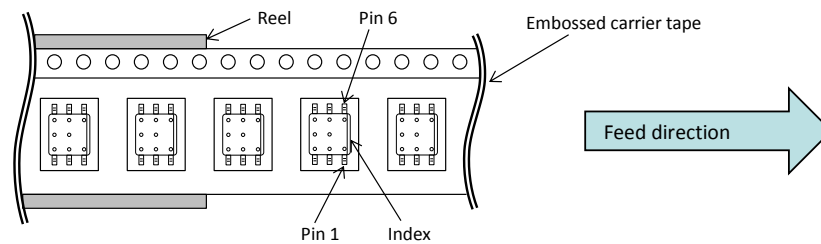

19. Footprint for PCB (for Reference)

Sensor Code	Footprint
AG3xF	

Notes:

- *1) These footprints are for reference. Please evaluate well these footprints, before your mass production.
- *2) When designing your PCB, please also refer to the outline diagrams.

20. Handling Notes

Plating of pins is silver (Ag). Silver has physical property that is discolored to black or brown by sulfur. There are notes for handling as below:

- To prevent discoloration of pins, please keep the devices sealed in static shielding bags before soldering.
- Do not solder the devices that have discolored pins.
- After soldering, pins would be discolored in black or brown in atmosphere. However it does not impact reliability of the device.

21. Notes

- Fujikura reserves all rights.
- This document is subject to change without notice.
- Limitation, usage, environment, standard warranty and so on are listed on Fujikura web site.
- Please refer to the latest specifications.

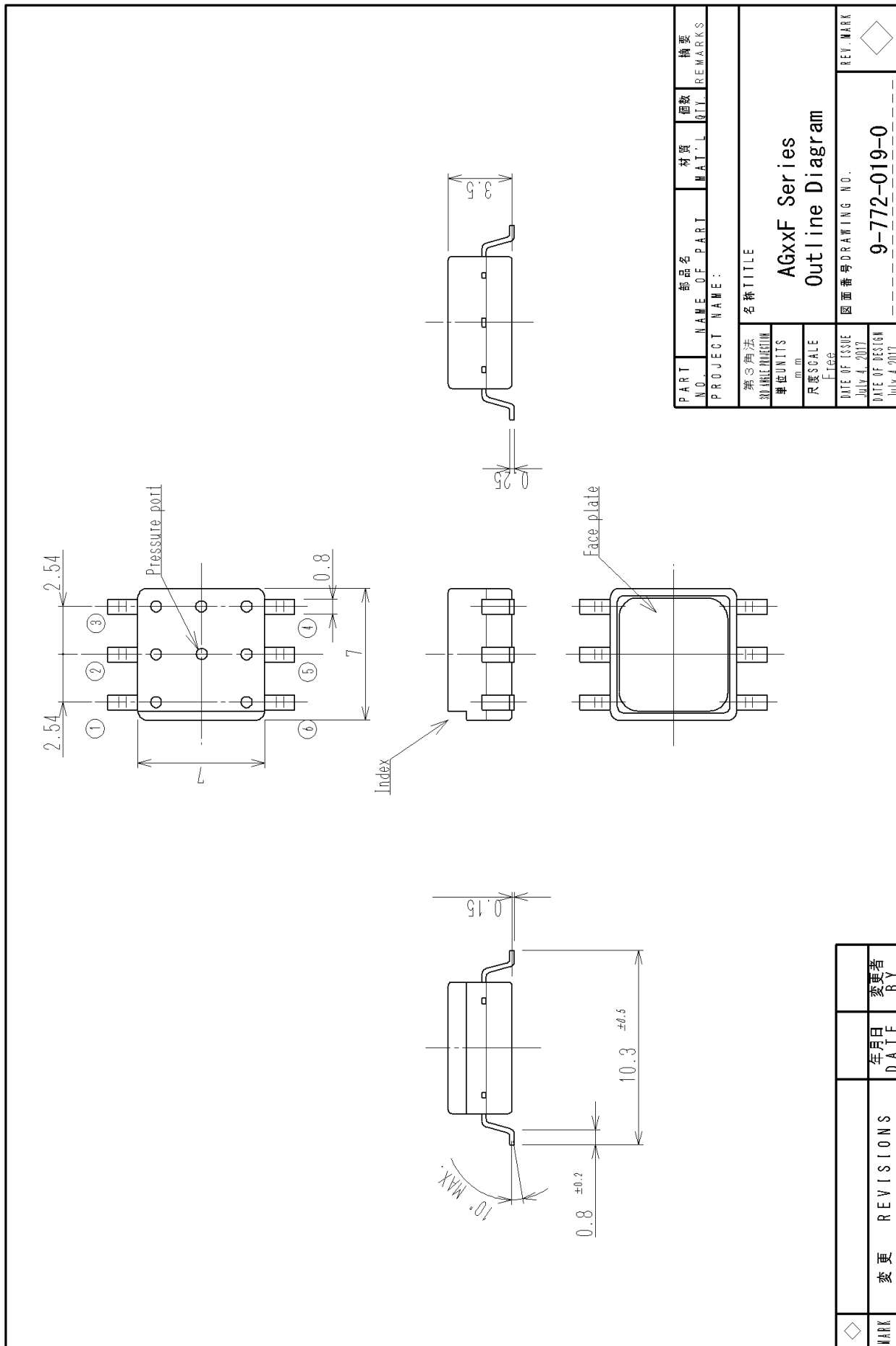

PART NO.	部品名	材質	数量	摘要
NAME OF PART	MAT'L	QTY	REMARKS	
PROJECT NAME:				
名称 TITLE				
AGxxF Series				
Outline Diagram				
图面番号 DRAWING NO.				
9-772-019-0				
REV. MARK				
◇				

MARK	变更 REVISIONS	年月日 DATE	变更者 BY
◇			

Headquarter Switzerland:
Angst+Pfister Sensors and Power AG

Thurgauerstrasse 66
CH-8050 Zurich
Phone +41 44 877 35 00
sensorsandpower@angst-pfister.com

Office Germany:
Angst+Pfister Sensors and Power
Deutschland GmbH
Edisonstraße 16
D-85716 Unterschleißheim
Phone +49 89 374 288 87 0
sensorsandpower.de@angst-pfister.com



We are here for you. Addresses and Contacts.

Sales Germany & Austria

Geometrical sensors
Other products

Kurt Stritzelberger
Phone +49 89 374 288 87 22
kurt.stritzelberger@angst-pfister.com

Pressure sensors
Other products

Gerhard Vetter
Phone +49 89 374 288 87 26
gerhard.vetter@angst-pfister.com

Gas sensors and modules

Peter Felder
Phone +41 44 877 35 05
peter.felder@angst-pfister.com

Sales Switzerland & Liechtenstein

Postcode 3000 – 9999

Basil Frei
Phone +41 44 877 35 18
basil.frei@angst-pfister.com

Postcode 1000 – 2999

Christian Mohrenstecher
Phone +41 76 444 57 93
christian.mohrenstecher@angst-pfister.com

Sales International Key Accounts

Peter Felder
Phone +41 44 877 35 05
peter.felder@angst-pfister.com

Sales Other Countries / Product Management

Pressure Sensors
Load Cells

Philipp Kistler
Phone +41 44 877 35 03
philipp.kistler@angst-pfister.com

Gas sensors
Gas sensor modules

Dr. Thomas Clausen
Phone +49 89 374 288 87 24
thomas.clausen@angst-pfister.com

Flow / Level / Medical products

Dr. Adriano Pittarelli
Phone +49 89 374 288 87 67
adriano.pittarelli@angst-pfister.com

Power supplies

Sebastiano Leggio
Phone +41 44 877 35 06
sebastiano.leggio@angst-pfister.com

Linear position sensors
Angle sensors

Eric Letsch
Phone +41 44 877 35 14
eric.letsch@angst-pfister.com

Accelerometers
Sensor elements

Christoph Kleye
Phone +49 89 374 288 87 61
christoph.kleye@angst-pfister.com

Drive technology
CH Postcode 5000 – 9999 / DE

Roman Homa
Phone +41 76 444 00 86
roman.homa@angst-pfister.com

Drive technology
CH Postcode 1000 – 4999 / AT / IT / FR

Christian Mohrenstecher
Phone +41 76 444 57 93
christian.mohrenstecher@angst-pfister.com

Harald Thomas
Phone +49 89 374 288 87 23
harald.thomas@angst-pfister.com