

Battery Backup Multi-turn Absolute Encoder

Hollow shaft type **Model : 37HA-MB**

■ Features

- 39-bits resolution: 16-bits battery backup multi-turn & 23-bits optical single-turn
- Built-in communication protocol (option): BiSS C mode, SSI mode & RS-485 half-duplex
- Overall encoder outer diameter $\varnothing 37$ mm and typical mounting height 28 mm
- Supporting standard hollow taper shaft, short hollow taper shaft and $\frac{1}{4}$ inch, 6mm and 8mm diameter of the hollow blind shaft options.



■ Model

37HA-MB - - **000-00E**

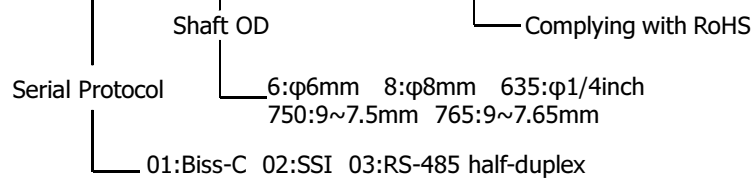

■ Specification

1. Basic specification

General		
Outside diameter	37mm	At housing
Height	27.6mm	From Motor Mounting Surface
Bearing	With Bearing	
Shaft	Hollow shaft: $\varnothing 1/4, \varnothing 6, \varnothing 8$	
	Taper shaft: $\varnothing 9$ - $\varnothing 7.5$ mm; 1:10 $\varnothing 9$ - $\varnothing 7.65$ mm; 1:10	
Measuring Methods	Optical transparent / Absolute	
Electrical		
Single-turn Resolution	23bits (8,388,607 counts)	
Multi-turn Resolution	16bits (65,535 counts)	
Main Supply Voltage	+5.0V $\pm 10\%$	
Main Supply Current	Typical 115mA	Without load, Ta=+25°C
External Battery Voltage	Typical +3.6V Max +4.5V	
External Battery Current	Typical 95uA	Ta=+25°C, No shaft rotation
Electrically Permissible Speed	$\leq 6,000$ min ⁻¹	
Electrically Permissible Acceleration	Normal mode: $\leq 8.0 \times 10^4$ rad/s ²	
	Battery mode: $\leq 4.0 \times 10^4$ rad/s ²	
Data Interface	BiSS-C, SSI, RS-485 half-duplex	

37HA-MB Series Datasheet (E)

- Note: 1. Normal mode: Encoder operates on encoder main power supply.
2. Battery mode: Encoder operates in "OFF" State, while multi-turn data is tracked by battery circuitry.

Mechanical		
System Accuracy	Typical ± 80 Arc-sec	With electrical correction, $T_a = +25^\circ\text{C}$
Mechanical Permissible Speed	$\leq 6,000\text{min}^{-1}$	
Mechanical Permissible Acceleration	$\leq 8.0 \times 10^4 \text{ rad/s}^2$	
Moment of inertia	$\leq 1.0 \times 10^{-6} \text{ kgm}^2$	
Shaft Radial Play	$\leq \pm 0.05 \text{ mm}$	
Shaft Axial Play	$\leq \pm 0.1 \text{ mm}$	
Starting torque	$\leq 9.8 \times 10^{-3} \text{ N.m}$ $T_{amb} = 25^\circ\text{C}$	
Environmental		
Operating Temperature Range	$-20 \sim +105^\circ\text{C}$	
Storage Temperature Range	$-20 \sim +105^\circ\text{C}$	
Vibration	$\leq 98\text{m/s}^2$ 10 to 2000Hz	Per IEC 60068-2-6
Shock	$\leq 1960\text{m/s}^2$ 6ms; Half Sine	Per IEC 60068-2-27
Protection	IP40	
Weight	0.047kg ($\pm 10\%$)	
Relative Air Humidity (Non-Condensing)	RH 90 %	$T_a = +40^\circ\text{C}$
Others		
Counting Direction	Increase with Counter Clockwise (CCW) shaft rotation, view from coupling end (Figure 1)	
External Battery Recommendation	3.60V/ 2,000mAh Lithium battery	
External Battery Alarm	Typical 3.10V $\pm 0.1\text{V}$	
System Down Error	Typical 2.90V $\pm 0.25\text{V}$	
Multi-turn value by Counter Clear	0	
Internal Memory	EEPROM	
Usable Memory Area	5Kbit	
Initialization Time	500ms	

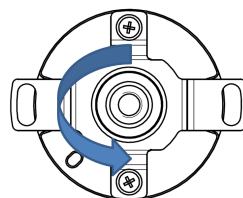

Figure 1

Note: Exposure to absolute maximum rating conditions for extended periods may affect reliability.

Interface Diagram

The following are examples of the circuit diagram of full-duplex and half-duplex transceiver.

Full-duplex transceiver (BiSS C mode / SSI mode protocol):

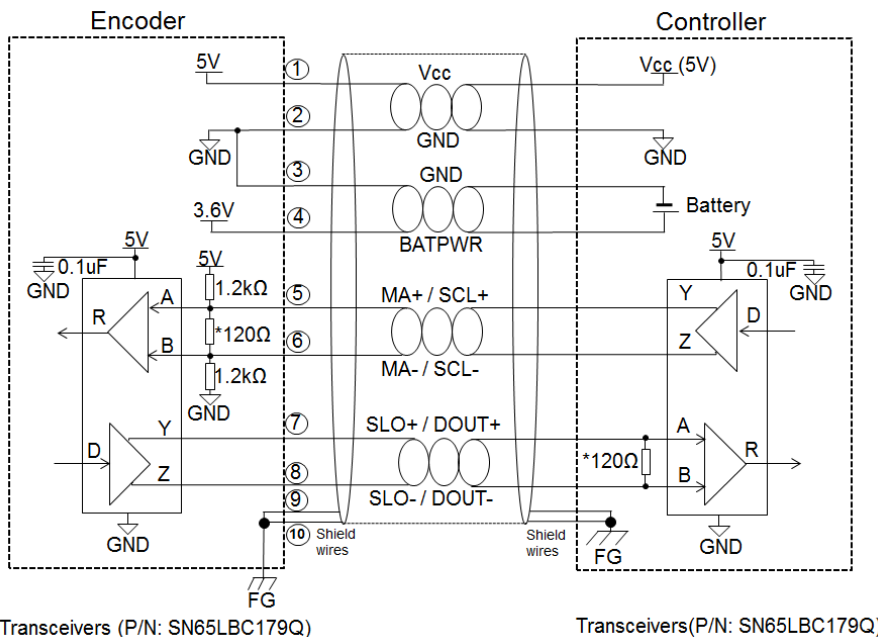

Transceivers (P/N: SN65LBC179Q)

Transceivers(P/N: SN65LBC179Q)

Figure 2: Circuit diagram of full-duplex transceiver

Half-duplex transceiver (RS-485 half-duplex protocol):

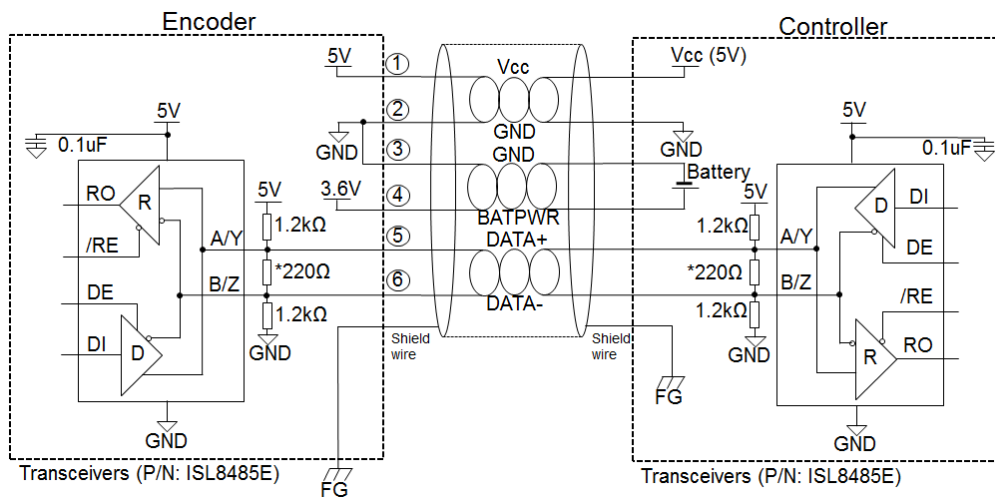

Transceivers (P/N: ISL8485E)

Transceivers (P/N: ISL8485E)

Figure 3: Circuit diagram of half-duplex transceiver

Note:

- 1) Termination resistor, *120ohm and *220ohm are recommended but may depends on the characteristic impedance of cable used.
- 2) Recommended to connect encoder chassis and cable shield to frame ground (FG) in application for enhanced noise immunity in harst operating condition.

37HA-MB Series Datasheet (E)

■ Connector Output Assignment

Pin	BiSS-C mode protocol (Output: 10 pins connector)	SSI mode protocol (Output: 10 pins connector)	RS-485 half-duplex protocol (Output: 7 pins connector)
1	VCC, Encoder Supply	VCC, Encoder Supply	VCC, Encoder Supply
2	GND, Ground	GND, Ground	GND, Ground
3	GND (External Battery)	GND (External Battery)	GND (External Battery)
4	BATPWR (External Battery)	BATPWR (External Battery)	BATPWR (External Battery)
5	MA+	SCL+	DATA+
6	MA-	SCL-	DATA-
7	SLO+	DOUT+	Cable Shield, Connect to Chassis
8	SLO-	DOUT-	N/A
9	Cable Shield, Connect to Chassis	Cable Shield, Connect to Chassis	N/A
10	Cable Shield, Connect to Chassis	Cable Shield, Connect to Chassis	N/A

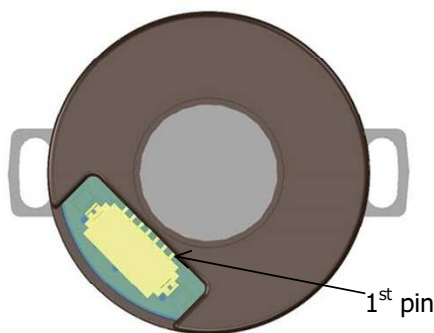

Figure 4: 7pins Connector Pin Assignment

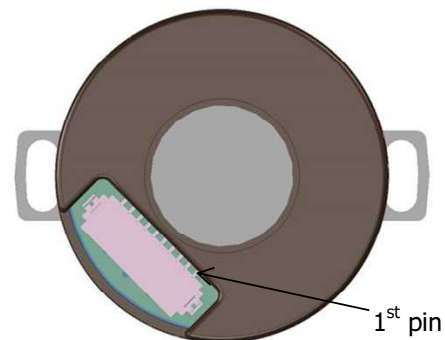

Figure 5: 10pins Connector Pin

*Recommended mating connector:

Hirose Part No : DF13-7S-1.25C for 7pins connector and DF13-10S-1.25C for 10 pins connector
(CL No.536-0006-8)

Hirose (Terminal Pin for Wire 26~30AWG): DF13-2630SCF (CL No.536-0300-5)

37HA-MB Series Datasheet (E)

■ Mechanical Drawing

Hollow Blind Shaft Option (Φ8mm)

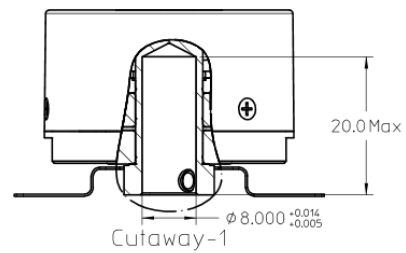
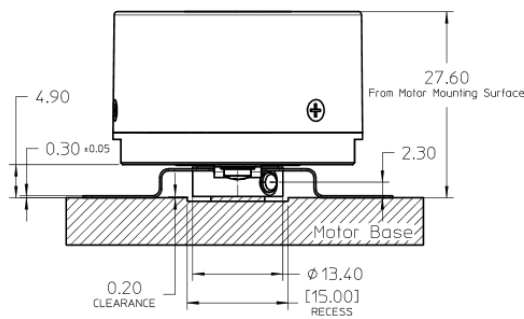
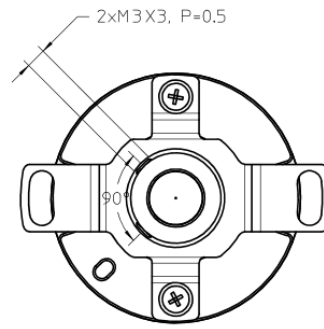
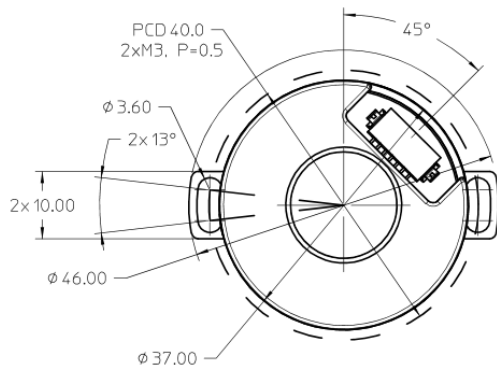

Recommended Shaft and Mounting Requirement

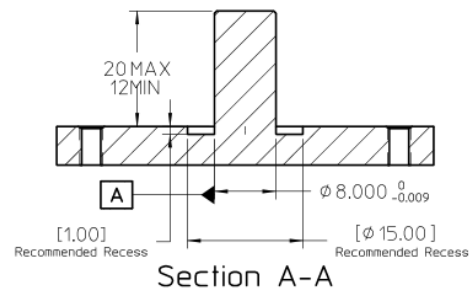
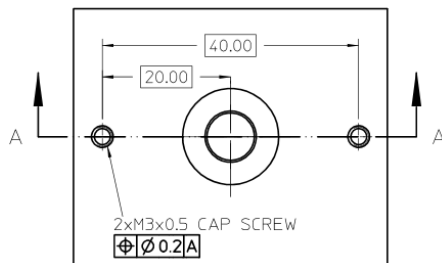

Note:

1. Dimensions are in millimeters.
2. 3rd Angle Projection.
3. Unless otherwise specified, all tolerances are within ±0.5 mm.
4. Recommended to have a recess on motor mounting surface to prevent encoder shaft interference with motor base.

37HA-MB Series Datasheet (E)

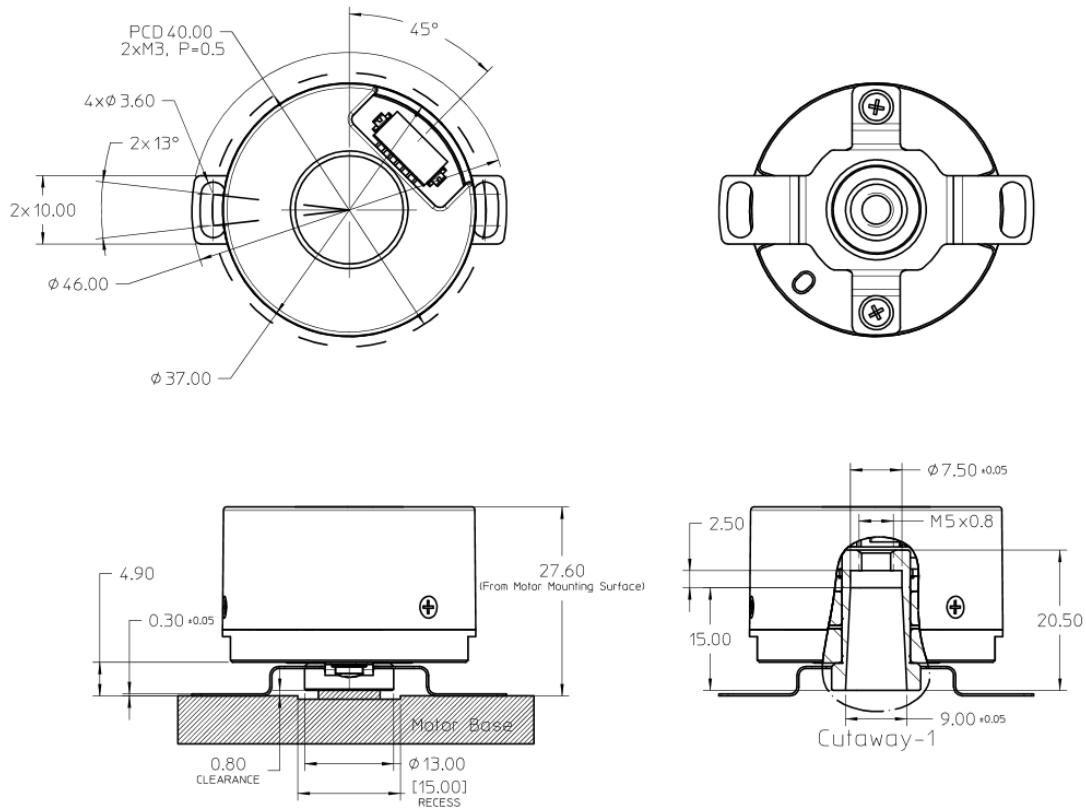
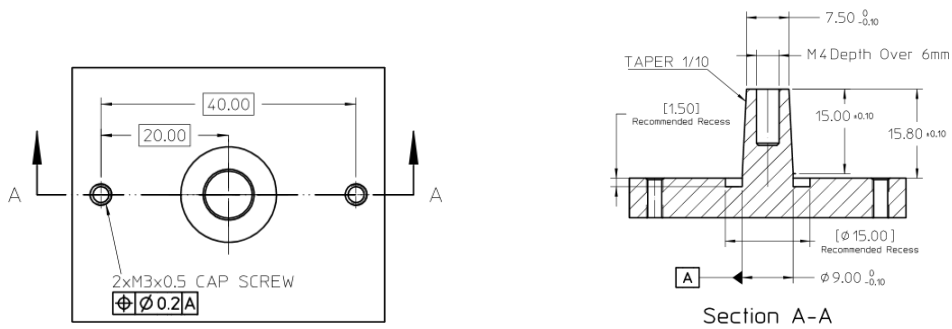
Standard Hollow Taper Shaft Option ($\Phi 9$ - $\Phi 7.5$ mm; 1:10)**Recommended Shaft and Mounting Requirement****Note:**

1. Dimensions are in millimeters.
2. 3rd Angle Projection.
3. Unless otherwise specified, all tolerances are within ± 0.5 mm.
4. Recommended to have a recess on motor mounting surface to prevent encoder shaft interference with motor base.

37HA-MB Series Datasheet (E)

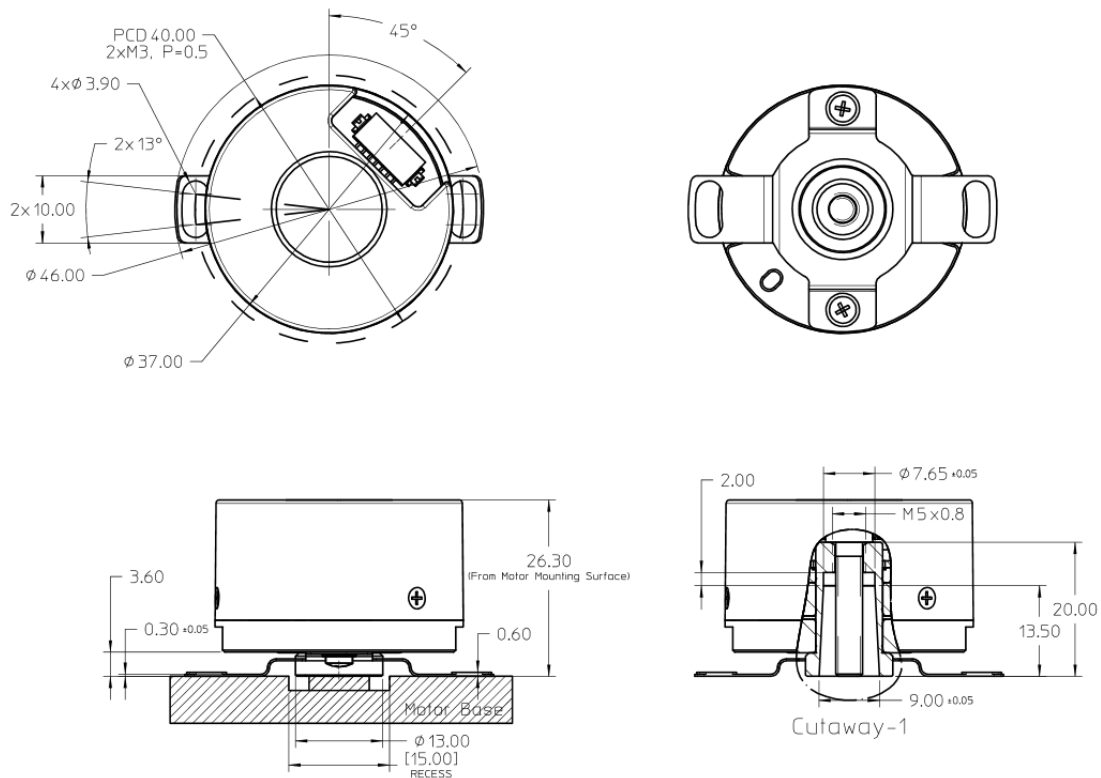
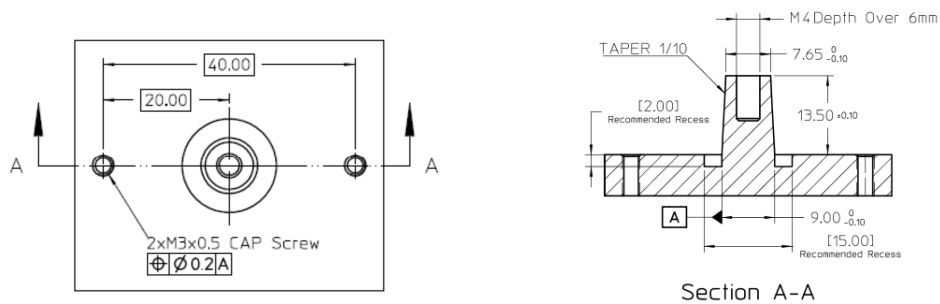
Short Hollow Taper Shaft Option ($\Phi 9$ - $\Phi 7.65$ mm; 1:10)**Recommended Shaft and Mounting Requirement****Note:**

1. Dimensions are in millimeters.
2. 3rd Angle Projection.
3. Unless otherwise specified, all tolerances are within ± 0.5 mm.
4. Recommended to have a recess on motor mounting surface to prevent encoder shaft interference with motor base.

Applications

- Robotics
- Factory automation
- CNC machine tool

NOTE

These encoders are not recommended for use in safety critical applications. E.g. ABS braking systems, power steering, life support systems and critical care medical equipment. Please contact sales representative if more clarification is needed.

Headquarter Switzerland:
Angst+Pfister Sensors and Power AG

Thurgauerstrasse 66
CH-8050 Zurich
Phone +41 44 877 35 00
sensorsandpower@angst-pfister.com

Office Germany:
Angst+Pfister Sensors and Power
Deutschland GmbH
Edisonstraße 16
D-85716 Unterschleißheim
Phone +49 89 374 288 87 0
sensorsandpower.de@angst-pfister.com



We are here for you. Addresses and Contacts.

Sales Germany & Austria

Geometrical sensors
Other products

Kurt Stritzelberger
Phone +49 89 374 288 87 22
kurt.stritzelberger@angst-pfister.com

Pressure sensors
Other products

Gerhard Vetter
Phone +49 89 374 288 87 26
gerhard.vetter@angst-pfister.com

Gas sensors and modules

Peter Felder
Phone +41 44 877 35 05
peter.felder@angst-pfister.com

Sales Switzerland & Liechtenstein

Postcode 3000 – 9999

Basil Frei
Phone +41 44 877 35 18
basil.frei@angst-pfister.com

Postcode 1000 – 2999

Christian Mohrenstecher
Phone +41 76 444 57 93
christian.mohrenstecher@angst-pfister.com

Sales International Key Accounts

Peter Felder
Phone +41 44 877 35 05
peter.felder@angst-pfister.com

Sales Other Countries / Product Management

Pressure Sensors
Load Cells

Philipp Kistler
Phone +41 44 877 35 03
philipp.kistler@angst-pfister.com

Gas sensors
Gas sensor modules

Dr. Thomas Clausen
Phone +49 89 374 288 87 24
thomas.clausen@angst-pfister.com

Flow / Level / Medical products

Dr. Adriano Pittarelli
Phone +49 89 374 288 87 67
adriano.pittarelli@angst-pfister.com

Power supplies

Sebastiano Leggio
Phone +41 44 877 35 06
sebastiano.leggio@angst-pfister.com

Linear position sensors
Angle sensors

Eric Letsch
Phone +41 44 877 35 14
eric.letsch@angst-pfister.com

Accelerometers
Sensor elements

Christoph Kleye
Phone +49 89 374 288 87 61
christoph.kleye@angst-pfister.com

Drive technology
CH Postcode 5000 – 9999 / DE

Roman Homa
Phone +41 76 444 00 86
roman.homa@angst-pfister.com

Drive technology
CH Postcode 1000 – 4999 / AT / IT / FR

Christian Mohrenstecher
Phone +41 76 444 57 93
christian.mohrenstecher@angst-pfister.com

Harald Thomas
Phone +49 89 374 288 87 23
harald.thomas@angst-pfister.com